

4.1 ANALOG TO DIGITAL CONVERTER

Successive Approximation type ADC is the most widely used and popular ADC method. The conversion time is maintained constant in successive approximation type ADC, and is proportional to the number of bits in the digital output, unlike the counter and continuous type A/D converters. The basic principle of this type of A/D converter is that the unknown analog input voltage is approximated against an n-bit digital value by trying one bit at a time, beginning with the MSB. The principle of successive approximation process for a 4-bit conversion is explained here. This type of ADC operates by successively dividing the voltage range by half, as explained in the following steps.

The MSB is initially set to 1 with the remaining three bits set as 000. The digital equivalent voltage is compared with the unknown analog input voltage.

If the analog input voltage is higher than the digital equivalent voltage, the MSB is retained as 1 and the second MSB is set to 1. Otherwise, the MSB is set to 0 and the second MSB is set to 1. Comparison is made as given in step (1) to decide whether to retain or reset the second MSB.

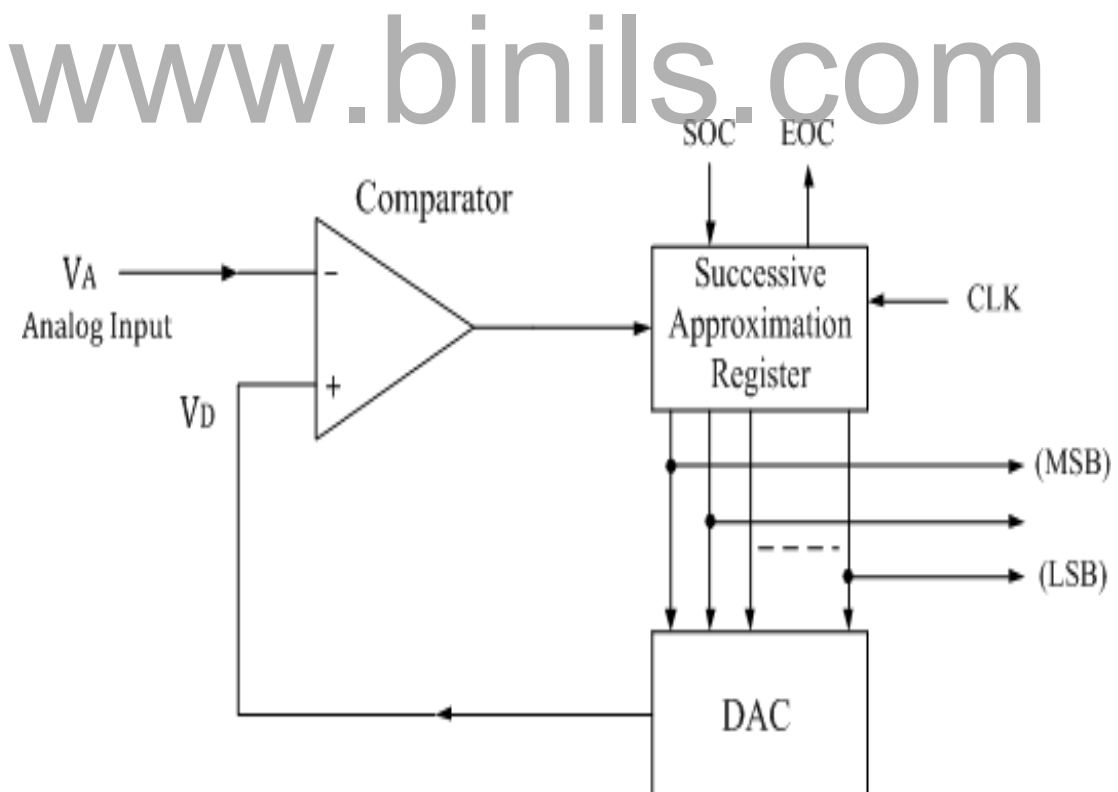

It consists of a successive approximation register (SAR), DAC and comparator. The output of SAR is given to n-bit DAC. The equivalent analog output voltage of DAC, V_D is applied to the non-inverting input of the comparator. The second input to the comparator is the unknown analog input voltage V_A . The output of the comparator is used to activate the successive approximation logic of SAR. When the start command is applied, the SAR sets the MSB to logic 1 and other bits are made logic 0, so that the trial code becomes 1000.

Advantages:

1. Conversion time is very small.
2. Conversion time is constant and independent of the amplitude of the analog input signal V_A .

Disadvantages:

1. Circuit is complex.
2. The conversion time is more compared to flash type ADC.

Applications

The SAR ADC will used widely data acquisition techniques at the sampling rates higher than 10KHz.

www.binils.com