

binils.com

DEPARTMENT OF  
**MECHANICAL ENGINEERING**

**Welding** is a process of joining two metal pieces as a result of significant diffusion of the atoms of the welded pieces into the joint (weld) region. Welding is carried out by heating the joined pieces to melting point and fusing them together (with or without filler material) or by applying pressure to the pieces in cold or heated state.

### Classification of welding processes

#### Arc welding

- Carbon Arc Welding;
- Shielded Metal Arc Welding (SMAW);
- Submerged Arc Welding (SAW);
- Metal Inert Gas Welding (MIG, GMAW);
- Tungsten Inert Gas Arc Welding (TIG, GTAW);
- Electroslag Welding (ESW);
- Plasma Arc Welding (PAW);

#### Resistance Welding (RW);

- Spot Welding (RSW);
- Flash Welding (FW);
- Resistance Butt Welding (UW) ;
- Seam Welding (RSEW);

#### Gas Welding (GW);

- Oxyacetylene Welding (OAW);
- Oxyhydrogen Welding (OHW);
- Pressure Gas Welding (PGW);

#### Solid State Welding (SSW);

- Forge Welding (FOW);
- Cold Welding (CW);
- Friction Welding (FRW);
- Explosive Welding (EXW);
- Diffusion Welding (DFW);
- Ultrasonic Welding (USW);

#### Thermo-chemical Welding

- Thermit Welding (TW)
- Atomic Hydrogen welding.

#### Radiant energy welding

- Electron Beam Welding (EBW);
- Laser Welding (LW).

### Commonly Welded Base Metals - Metals can be classified as

#### 1. Ferrous

2. Nonferrous. Ferrous materials contain iron and the one element people use more than all others is Iron. Ferrous materials are the most important metals/alloys in the metal lurgical and mechanical industries because of their very extensive use.

Ferrous materials finding day to day welding applications are:

1. Wrought Iron.
2. Cast Iron.

3. Carbon Steel (Low, Medium and High Carbon Steels).
4. Cast Steels.
5. Alloy Steels.
6. Stainless Steels, etc.

Nonferrous materials are those that are not iron based.

Like ferrous materials, nonferrous materials also find extensive industrial applications.

Nonferrous materials finding day to day welding applications are :

7. Aluminium and its alloys.
8. Copper and its alloys.
9. Magnesium and its alloys.
10. Nickel and its alloys.
11. Zinc and its alloys, etc

### **Advantages of Welding -**

- (i) A good weld is as strong as the base metal.
- (ii) General welding equipment is not very costly.
- (iii) Portable welding equipments are available.
- (iv) Welding permits considerable freedom in design.
- (v) A large number of metals/alloys both similar and dissimilar can be joined by welding.
- (vi) Welding can join workpieces through spots, as continuous pressure tight seams, end to end and in a number of other configurations.
- (viii) Welding can be mechanized.

### **Disadvantages of Welding -**

- (i) Welding gives out harmful radiations (light) fumes and spatter.
- (ii) Welding results in residual stresses and distortion of the work pieces.
- (iii) Jigs and fixtures are generally required to hold and position the parts to be welded.
- (iv) Edge preparation of the workpieces is generally required before welding them.
- (v) A skilled welder is a must to produce a good welding job.
- (vi) Welding heat produces metallurgical changes. The structure of the welded joint is not same as that of the parent metal.
- (vii) A welded joint for many reasons, needs stress relief heat treatment.

**Welding Compared to Riveting and Casting -** Bridges, ships and boilers which were previously riveted are now welded. Machine tool beds which were earlier cast are now fabricated using welding. In many fields welding has replaced riveting and casting processes. Some of the reasons, for the same, are as follows:

1. Welding is more economical and is a much faster process as compared to both casting and riveting.
2. Fabricated mild steel structures are lighter as compared to (cast) cast iron ones.
3. Fabricated mild steel structures have more tensile strength and rigidity as compared to (cast) cast iron ones.
4. Welding can join dissimilar metals and thus in a complicated structure (depending upon strength or other criteria) different parts of the structure can be fabricated with different materials.
5. For the same complexity of a component the design of a welded structure is simpler as compared to that of a cast part. Standard rolled sections help considerably in fabricating different structures by welding.
6. Being noiseless as compared to riveting, welding finds extensive use, when making modifications, additions or extensions in hospital buildings.
7. Cost of pattern making and storing is eliminated.
8. As compared to casting and riveting fewer persons are involved in a welding fabrications.

9. Welding fabrication involves inventory, much less as compared to casting and since no patterns are involved, the chances of obsolescence are negligible.
10. Against riveted construction welding fabrication involves less cost of handling.
11. Structural shapes not easily obtainable with riveting or casting can be produced by welding without much difficulty.
12. Welding design involves lower costs and it is very flexible also.
13. Fabrication by welding saves machining costs involved in cast parts.
14. Welded pressure vessels are more (fluid and) pressure tight as compared to riveted ones. Moreover, for pressure tightness, the rivets must be calked.
15. Ratio between weight of weld metal and the entire weight of structure is much lesser than the ratio between the weight of rivets and the entire weight of the structure.  
Welded structures are comparatively lighter than corresponding riveted ones.
16. Cover plates, connecting angles, gusset plates, etc., needed in riveted construction are not required when welding the structures.
17. Members of such shapes that present difficulty for riveting can be easily welded.
18. Welding can be carried out at any point on a structure, but, riveting always requires enough clearance to be done.
19. A welded structure possesses a better finish and appearance than the corresponding riveted structure.
20. Layout for punching or drilling of holes is not required in welding.
21. Drilling holes in the plates in order to accommodate rivets, breaks material continuity and weakens a riveted structure.
22. Cost of standard rolled sections is much less as compared to that of a casting with the result that welded structures involve less material costs.
23. Making changes in an already cast or riveted structure is extremely difficult, if not impossible. On the other hand a welded structure can be modified or repaired without much difficulty.
24. Welding can produce a 100% efficient joint which is difficult to make by riveting.
25. Riveting high strength steels presents the problem of acquiring high strength steel rivets.
26. Old structures can easily be reinforced by welding.

Whereas welding claims its supremacy, casting, however has got its own good points. For example,

- (i) a product is obtained as one piece, ,
- (ii) thermal effects as in welding are not there,
- (iii) very heavy and bulky parts like those of power plants and mill housings which are otherwise difficult to fabricate can be cast.

**Practical Applications of Welding** - Welding has been employed in Industry as a tool for:

- (a) Regular fabrication of automobile cars, aircrafts, refrigerators, etc.
- (b) Repair and maintenance work, e.g., joining broken parts, rebuilding Worn out components, etc. A few important applications of welding are listed below:

**1. Aircraft Construction:**

- (a) Welded engine mounts.
- (b) Turbine frame for jet engine.
- (c) Rocket motor fuel and oxidizer tanks.
- (d) Ducts, fittings, cowling components, etc

**2. Automobile Construction:**

- (a) Arc welded car wheels.
- (b) Steel rear axle housing.
- (c) Frame side rails.
- (d) Automobile frame, brackets, etc.

**3. Bridges:**

- (a) Pier construction.
- (b) Section lengths.
- (c) Shop and field assembly of lengths, etc.

**4. Buildings:**

- (a) Column base plates.
- (b) Trusses.
- (c) Erection of structure, etc.

**5. Pressure Vessels and Tanks:**

- (a) Clad and lined steel plates.
- (b) Shell construction.
- (c) Joining of nozzle to the shell, etc.

**6. Storage Tanks:**

- (a) Oil, gas and water storage tanks

**7. Rail Road Equipment: Locomotive**

- (a) Under frame.
- (b) Air receiver.
- (c) Engine.
- (d) Front and rear hoods, etc.

**8. Piping and Pipelines:**

- (a) Rolled plate piping.
- (b) Open pipe joints.
- (c) Oil, gas and gasoline pipe lines, etc.

**9. Ships:**

- (a) Shell frames.
- (b) Deck beams and bulkhead stiffeners.
- (c) Girders to shells.
- (d) Bulkhead webs to plating, etc.

**10. Trucks and trailers.**

1. Machine tool frames, cutting tools and dies.
2. Household and office furniture.
3. Earth moving machinery and cranes.
4. In addition, arc welding finds following applications in repair and maintenance work:
5. Repair of broken and damaged components and machinery such as tools, punches, dies, gears, shears, press and machine tools frames.
6. Hard facing and rebuilding of worn out or undersized (costly) parts rejected during inspection.
7. Fabrication of jigs, fixtures, clamps and other work holding devices.

## WELDING POSITION

PA - flat position

PB - horizontal vertical position

PC - horizontal position

PD - horizontal overhead position

PE - overhead position

PF - vertical up position

PG - vertical down position

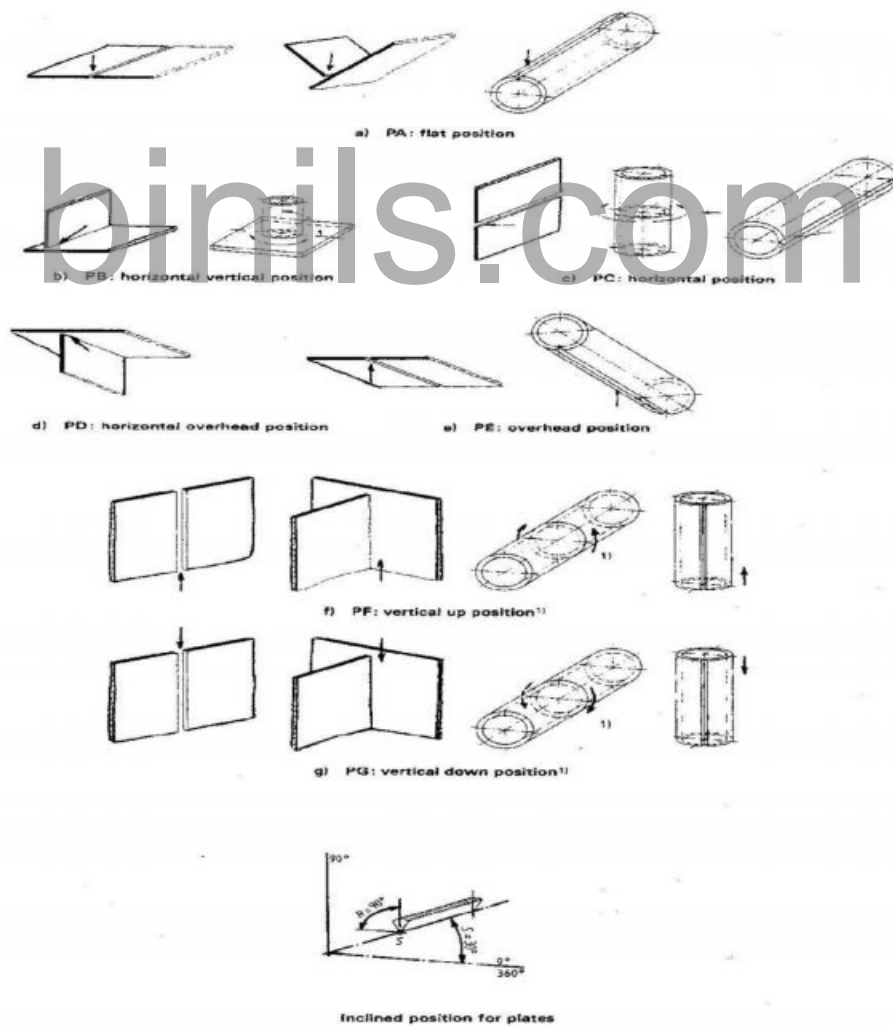

Examples of welding position (from EN ISO 6947)

## GAS WELDING PROCESSES

**Gas Welding** is a welding process utilizing heat of the flame from a welding torch. The torch mixes a fuel gas with Oxygen in the proper ratio and flow rate providing combustion process at a required temperature. The hot flame fuses the edges of the welded parts, which are joined together forming a weld after Solidification.

The flame temperature is determined by a type of the fuel gas and proportion of oxygen in the combustion mixture: 4500°F - 6300°F (2500°C - 3500°C). Depending on the proportion of the fuel gas and oxygen in the combustion mixture, the flame may be chemically neutral (stoichiometric content of the gases), oxidizing (excess of oxygen), carburizing (excess of fuel gas).

Filler rod is used when an additional supply of metal to weld is required. Shielding flux may be used if protection of weld pool is necessary.

Most of commercial metals may be welded by Gas Welding excluding reactive metals (titanium, zirconium) and refractory metals (tungsten, molybdenum).

The most popular methods of Gas Welding are:

**Air Acetylene Welding (AAW)**

**Oxy-acetylene Welding (OAW)**

**Oxy-hydrogen Welding (OHW)**

**Pressure Gas Welding (PGW)**

**Gas Welding Processes and Equipments** - Gas welding is a fusion welding process. It joins metals, using the heat of combustion of an oxygen/air and fuel gas (i.e acetylene, hydrogen, propane or butane) mixture. The intense heat (flame) thus produced melts and fuses together the edges of the parts to be welded, generally with the addition of a filler metal.

### Oxy Acetylene Welding

**Principle of Operation** - When acetylene is mixed with oxygen in correct proportions in the welding torch and ignited, the flame resulting at the tip of the torch is sufficiently hot to melt and join the parent metal.

The oxyacetylene flame reaches a temperature of about 3200°C and thus can melt all commercial metals which, during welding, actually flow together to form a complete bond. A filler metal rod is generally added to the molten metal pool to build up the seam slightly for greater strength. Oxyacetylene welding does not require the components to be forced together under pressure until the weld forms and solidifies.

### Types of flames

The proportions of acetylene and oxygen in the gas mixture are an important factor in oxyfuel gas welding. At a ratio of 1:1, that is, when there is no excess oxygen, it is considered to be a neutral flame. With a greater oxygen supply, it becomes an oxidizing flame. This flame is harmful, especially for steels, because it oxidizes the steel. Only in copper and copper-base alloys is an oxidizing flame desirable because a thin protective layer of slag forms over the molten metal. If the supply of oxygen is lowered, it becomes a reducing or carburizing flame. The temperature of a reducing, or excess-acetylene, flame is lower. Hence it is suitable for applications requiring low heat, such as brazing, soldering, and flame hardening.



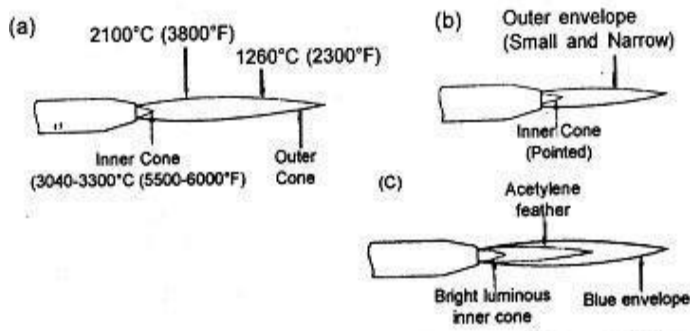

Other fuel gases such as hydrogen and methylacetylene propadiene can be used in oxyfuel gas welding. However, the temperatures developed are low, and hence they are used for welding metals with low melting points, such as lead, and parts that are thin and small. The flame with hydrogen gas is colorless, making it difficult to adjust the flame by eyesight. Other gases, such as natural gases, propane, and butane, are not suitable for oxyfuel welding because of the low heat output or because the flame is oxidizing.

Figure shows Three types of oxyacetylene flames used in oxyfuel gas welding and cutting operations: (a) neutral flame; (b) oxidizing flame; and (c) carburizing, or reducing, flame. The gas mixture is basically equal volumes of oxygen and acetylene.

### Gas Welding Equipment -

The basic equipments used to carry out gas welding are:

1. Oxygen gas cylinder.
2. Acetylene gas cylinder.
3. Oxygen pressure regulator.
4. Acetylene pressure regulator.
5. Oxygen gas hose(Blue).
6. Acetylene gas hose(Red).
7. Welding torch or blow pipe with a set of nozzles and gas lighter
8. Trolleys for the transportation of oxygen and acetylene cylinders
9. A set of keys and spanners.
10. Filler rods and fluxes.
11. Protective clothing for the welder (e.g., asbestos apron, gloves, goggles, etc.)

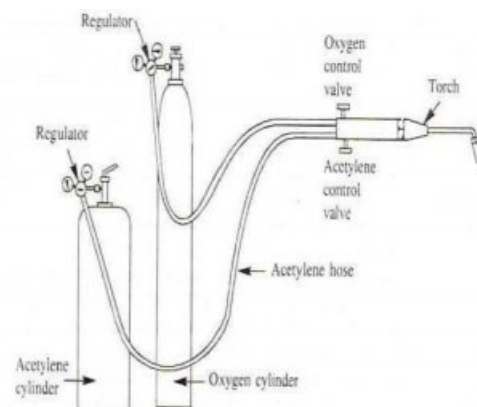
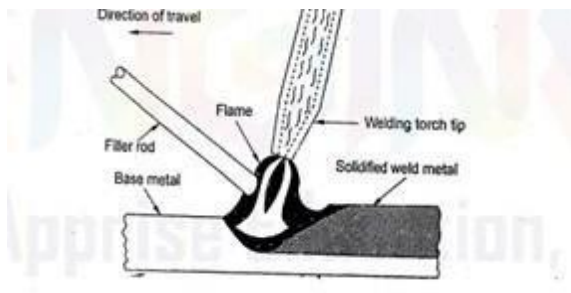



**Oxygen Gas Cylinder** - Oxygen cylinders are painted black and the valve outlets are screwed right handed. The usual sizes of oxygen cylinders are 3400, 5200 and 6800 litre. Oxygen cylinder is a solid drawn cylinder out of mild steel or alloy steel. Mild steel cylinder is charged to a pressure of  $13660 \text{ KN/m}^2$  (136.6 bar) and alloy steel cylinders to  $17240 \text{ KN/m}^2$  (172 bar).

The oxygen volume in a cylinder is directly proportional to its pressure. In other words, if the original pressure of a full oxygen cylinder drops by 5% during welding, it means 1/20 of the cylinder contents have been consumed.

Because of the possibility of the oxygen pressure becoming high enough to rupture the steel cylinder in case the temperature rises, an oxygen cylinder is equipped with a safety nut that allows the oxygen to drain slowly in the event the temperature increases the gas pressure beyond the safety load of the cylinder.

An oxygen cylinder has an inside diameter of 8.5" (21.6 cm), wall thickness 0.260" (0.650 mm) and length 51" (127.5 cm). In order to protect cylinder valve from getting damaged, a removable steel cap is screwed on the cylinder at all times. When the cylinder is not in use, the cylinder valve is kept closed when the cylinder is not in use and even when cylinder is empty.

**Acetylene Gas Cylinder** - An acetylene cylinder is painted maroon and the valves are screwed left handed; to make this easily recognisable they are chamfered or grooved. An acetylene cylinder is also a solid drawn steel cylinder which is charged to a pressure of  $1552 \text{ KN/m}^2$  (15.5 bar).

The usual size of acetylene cylinders are 2800 and 5600 litre. An acetylene cylinder has an inside diameter of 12" (30 cm), wall thickness 0.175" (0.438 mm) and a length of 40.5" (101.25 cm). An acetylene cylinder is filled with a spongy (porous) material such as balsa wood or some other absorptive material which is saturated with a chemical solvent called acetone. Since high pressure acetylene is not stable, it is dissolved in acetone, which has the ability to absorb a large volume of the gas and release it as the pressure falls. The small compartments in the porous material (filled in the cylinder) prevent the sudden decomposition of the acetylene throughout the mass, should it be started by local heating or other causes.

An acetylene cylinder is always kept upright for safety reasons. The acetone in the cylinder must not be permitted to enter the blowpipe, otherwise an explosion could result. The acetylene cylinder valve can only be opened with a special wrench and this wrench is kept in place whenever the cylinder is in use.

An acetylene cylinder has a number of fusible plugs, at its bottom, designed to melt at  $220^\circ\text{F}$  ( $104^\circ\text{C}$ ). These plugs melt and release the pressure in case the cylinder is exposed to excessive heat.

**Oxy Hydrogen and other Fuel Gas Welding** - Though oxyacetylene flame is the most versatile and hottest of all the flames produced by the combination of oxygen and other fuel gases, depending upon various factors as listed below, other gases such as Hydrogen, Propane, Butane, Natural gas, etc., may also be used for some welding and brazing applications. The factors are:

1. The type of material to be welded.
2. The required welding temperature.
3. Which fuel gas is readily available.
4. The relative cost of supply of the fuel gas.

Given below are the approximate flame temperatures of oxygen and various fuel gas combinations.

Oxyacetylene  $3200^\circ\text{C}$

Oxyhydrogen  $2500^\circ\text{C}$

Oxypropane  $2500^\circ\text{C}$

## Oxy-hydrogen Welding (OHW)

**Oxy-hydrogen Welding** is a Gas Welding process using a combustion mixture of Hydrogen (H<sub>2</sub>) and oxygen (O<sub>2</sub>) for producing gas welding flame.

Oxyacetylene flame has a temperature of about 4500°F (2500°C).  
Combustion reaction is as follows:

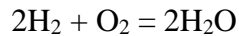

Oxyhydrogen Welding is used for joining metals with low melting points, like aluminum, magnesium, etc. **Hydrogen.** Oxyhydrogen flame is used to weld and braze metals only with low melting points, e.g., aluminium, magnesium, lead etc. The temperature of the hottest part of an oxy-hydrogen flame suitable for welding is only about 2500°C against 3200°C of an oxyacetylene flame.

In oxyhydrogen welding, if a higher temperature is obtained by increasing the oxygen supply, the flame becomes quite unsuitable for welding. Oxyhydrogen welding is therefore not used for welding steel. Hydrogen is available in compressed gas cylinders. Complete combustion of hydrogen requires an oxygen to hydrogen ratio of 1 to 2,

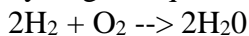

This gas mixture produces a strongly oxidizing flame. The oxyhydrogen flame is scarcely visible and there are no combustion zones as in oxyacetylene flame. Therefore it is impossible to obtain a neutral oxyhydrogen flame by the visible methods of flame adjustment. To avoid an oxidizing flame, the pressure regulators must be set to provide an assured excess of hydrogen. Since there is no carbon, the oxyhydrogen flame is only reducing (and never carburizing). The oxyhydrogen welding is similar to oxyacetylene welding with the difference that a special regulator is used for metering the hydrogen gas.

## Propane, Butane and Natural Gas

Propane and Butane are derived from petroleum. Natural gas is a low pressure fuel gas. Complete combustion of natural gas (methane) and propane is shown, respectively, by the following equations.

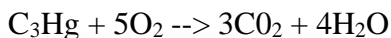
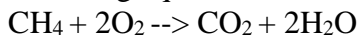

These fuel gases along with oxygen can be used to weld lower melting point metals, but their use in metal joining is usually limited to brazing. Natural gas can be used in soldering, brazing, preheating and cutting. Propane and Butane are used primarily in brazing. These gases are not used for welding steel.

Because, when the flame temperature is made high enough to weld steel, the flame atmosphere is excessively oxidizing, but when the ratio of oxygen to fuel gas is decreased to produce a carburising condition, flame temperature goes too low. Sometimes, LPG or liquified petroleum gas is also employed as a fuel gas for brazing, soldering and cutting metals.

## Air Acetylene Welding

### Definition.

Air acetylene welding is a gas welding process where in coalescence is produced by heating with a gas flame obtained from the combustion of acetylene with air, without the application of pressure and with or without the use of filler metal.

### **Principle of Operation**

It operates on the Bunsen burner principle, i.e., the acetylene flowing under pressure through a Bunsen jet aspirate the appropriate amount of air for combustion purposes. Acetylene is obtained from a cylinder through a pressure regulator and hose. As the acetylene flows through the torch it draws air from the atmosphere into it in order to obtain the oxygen necessary for combustion.

### **Applications.**

Since the temperature of airacetylene flame is substantially lower than that obtained when using any fuel gas and oxygen, airacetylene welding process is used for

- (i) Copper plumbing (soft soldering).
- (ii) Refrigeration and air-conditioning parts (silver brazing).
- (iii) Welding light sections of lead.

### **Pressure Gas Welding**

It is a Gas Welding, in which the welded parts are pressed to each other when heated by a gas flame. The process is similar to Resistance Butt Welding. Pressure Gas Welding does not require filler material. Pressure gas welding is used for joining pipes, rods, railroad rails.

### **Advantages of Gas Welding -**

1. It is probably the most versatile process. It can be applied to a wide variety of manufacturing and maintenance situations.
2. Welder has considerable control over the temperature of the metal in the weld zone. When the rate of heat input from the flame is properly coordinated with the speed of welding, the size, viscosity and surface tension of the weld puddle can be controlled, permitting the pressure of the flame to be used to aid in positioning and shaping the weld.
3. The rate of heating and cooling is relatively slow. In some cases, this is an advantage.
4. Since the sources of heat and of filler metal are separate, the welder has control over filler metal deposition rates. Heat can be applied preferentially to the base metal or the filler metal.
5. The equipment is versatile, low cost, self-sufficient and usually portable. Besides gas welding, the equipment can be used for preheating, post heating, braze welding, torch brazing and it is readily converted to oxygen cutting.
6. The cost and maintenance of the welding equipment is low when compared to that of some other welding processes

### **Disadvantages of Gas Welding -**

1. Heavy sections cannot be joined economically.
2. Flame temperature is less than the temperature of the arc.
3. Fluxes used in certain welding and brazing operations produce fumes that are irritating to the eyes, nose, throat and lungs.
4. Refractory metals (e.g., tungsten, molybdenum, tantalum, etc.) and reactive metals (e.g., titanium and zirconium) cannot be gas welded.
5. Gas flame takes a long time to heat up the metal than an arc.
6. Prolonged heating of the joint in gas welding results in a larger heat affected area. This often leads to increased grain growth, more distortion and, in some cases, loss of corrosion resistance.
7. More safety problems are associated with the handling and storing of gases.
8. Acetylene and oxygen gases are rather expensive.
9. Flux shielding in gas welding is not so effective as an inert gas shielding in TIG or MIG welding.

### Applications of Gas Welding -

1. For joining thin materials.
2. For joining materials in whose case excessively high temperatures or rapid heating and cooling of the job would produce unwanted or harmful changes in the metal.
3. For joining materials in whose case extremely high temperatures would cause certain elements in the metal to escape into the atmosphere.
4. For joining most ferrous and nonferrous metals, e.g., carbon steels, alloy steels, cast iron, aluminium, copper, nickel, magnesium and its alloys, etc.
5. In automotive and aircraft industries. In sheet metal fabricating plants, etc.

### Electrodes

Depending upon the material of the electrode, it may melt and supply filler metal; if it is non-consumable, a separate filler addition generally becomes necessary.

The Composition of the core wire depends upon the metal to be welded. For example, to weld mild steel, core wire of similar composition will be prepared, in order to get a homogeneous welded joint. The size or diameter of the core wire will depend upon the amount of weld metal to be deposited and on the type of joint or the gap to be bridged between the two plates to be welded. Higher currents will be required to weld with bigger diameter electrodes.

The length of the core wire is designed after considering rigidity, electrical resistance, the ease in welding and the diameter of the electrode. Generally thin and larger diameter electrodes are of shorter lengths and medium sized electrodes have bigger lengths. The reason is if thin electrodes are made longer they may bend and welding may not be carried out properly; and if bigger diameter electrodes are made long, their weight may increase too much to make welding operation inconvenient for the operator. In longer electrodes, electrical resistance and thus the heat generated in the electrode body increases, which may spoil the electrode covering. Diameter remaining same, an electrode of higher resistance material is normally made smaller in length.

**Non Consumable or Refractory Electrodes** - They are made up of high melting point materials like carbon (MP 6700°F), pure tungsten (MP 6150°F) or alloy tungsten. These electrodes do not melt away during welding. They maintain the arc which melts the base metal (as in TIG and 20 carbon arc welding). Strictly speaking, these electrodes cannot be called non consumable.

The electrode length goes on decreasing with the passage of time, because of vaporization and oxidation of the electrode material during welding. In welding processes using refractory electrodes, filler metal addition may or may not be needed, depending upon the plate thickness and the type of joint. First amongst the non-consumable electrodes are copper coated carbon or graphite electrodes. Copper coating increases the electrical conductivity or current conducting capacity of the electrodes. A comparison of carbon and graphite electrodes is given below

### Carbon Electrodes

1. Less expensive.
2. Carry less current.
3. Long life.
4. Arc control is comparatively difficult.
5. Material is hard and brittle.
6. Lesser electrical resistance.

### Graphite Electrodes

1. Comparatively costlier
2. Carry larger currents as compared to carbon electrodes.
3. Short life.
4. Simpler arc control.
5. Soft material.

## 6. Higher electrical resistance

Carbon or graphite electrodes ranging from 2 mm to 15 mm are employed for welding purposes. Next amongst non-consumable electrodes are, those of pure tungsten, (1 or 2%) thoriated or (0.3-0.5%) zirconiated tungsten electrodes. Alloying pure tungsten increases emissivity, resistance to contamination, arc stability, and electrode life. In addition, arc initiation is easier, electrode tip remains cooler (as compared to pure tungsten electrode), electrode consumption is less and there is a gain in current carrying capacity.

As compared to carbon electrodes, tungsten electrodes are much more expensive and alloy tungsten electrodes are still more costly. Tungsten/alloy tungsten electrodes ranging from 0.5 mm to 6 mm diameter are commonly available for welding purposes.

**Consumables Electrodes** - They are low melting point electrodes made up of different metals and their alloys. When the arc between the electrode and job is struck, the end of the electrode starts melting and transfers to the job in the form of droplets. The electrode itself adds filler metal. Droplets transferring (from electrode end and through arc) to the workpiece deposit there most of the heat generated as resistance heating in the electrode and of the arc.

Because of this reason a consumable electrode welding system possesses higher thermal efficiency (about 85%) as compared to that of a non consumable electrode welding arrangement (about 55%). Consumable electrodes may be of the following types.

### **Bare electrodes**

They consist of a metal or alloy wire without any flux coating on them.

### **Lightly coated electrodes**

Electrodes with a coating factor\* approximately 1.25 are termed as lightly coated electrodes. Medium coated electrodes. They are the electrodes with a coating factor about 1.45.

### **Heavily coated electrodes**

The coating factor is between 1.6 and 2.2 for heavily coated electrodes. Example: Citofine (A.O.). As compared to lightly coated electrodes, heavily coated ones find applications in severe conditions; they produce deeper penetrations and weld metal of high quality. In heavily coated electrodes, the core wire melts before the flux coating, giving rise to a cavity, hence producing arc constriction and arc heat concentration on the workpiece

Because of unstable arc, irregular metal transfer and atmospheric contamination, bare electrodes do not produce sound and satisfactory welds but still they find application where weld strength is not a primary consideration and it is difficult to carry post cleaning of the joint.

Covered Electrodes produce very well in heavy coated electrodes weld appearances, weld metal properties and defect free joints.

**Electrode Coating Ingredients and Their Functions** - The covering/coating on the core wire consists of many materials which perform a number of functions as listed below:

1. Slag forming ingredients, like silicates of sodium \*, potassium, magnesium, aluminium, iron oxide, china clay, mica etc., produce a slag which because of its light weight forms a layer on the molten metal and protects the same from atmospheric contamination.
2. Gas shielding ingredients, like cellulose, wood, wood flour, starch, calcium carbonate etc., form a protective gas shield around the electrode end, arc and weld pool.
3. Deoxidizing elements like ferro-manganese, and ferrosilicon, refine the molten metal.
4. Arc stabilizing constituents like calcium carbonate, potassium silicate, titanate, magnesium silicates, etc. add to arc stability and ease of striking the same.

5. Alloying elements like ferro alloys of manganese, molybdenum etc. may be added to impart suitable properties and strength to the weld metal and to make good the loss of some of the elements, which vaporize while welding.

6. Iron powder in the coating improves arc behaviour, bead appearance; helps increase metal deposition rate and arc travel speed. In addition, the electrode covering may perform the following functions:

7. The covering improves penetration and surface finish.

8. Core wire melts faster than the covering, thus forming a sleeve of the coating which constricts and produces an arc with high concentrated heat.

9. It limits spatter, produces a quiet arc and easily removable slag.

10. With proper constituents, the slag may have quick freezing property and thus make overhead and vertical welding easy.

11. Coating saves the welder from the radiations otherwise emitted from a bare electrode while the current flows through it during welding.

12. Suitable coating will improve metal deposition rates.

13. Proper coating ingredients produce weld metals resistant to hot and cold cracking.

When a suitable thickness of the flux gets adhered to the core wire, the fixture is raised and the flux is allowed to dry.

binils.com



## ARC WELDING PROCESSES

### METAL ARC WELDING

It is a process of joining two metal pieces by melting the edges by an electric arc. The electric arc is produced between two conductors. The electrode is one conductor and the work piece is another conductor. The electrode and the work piece are brought nearer with small air gap. (3mm app.)

When current is passed an electric arc is produced between the electrode and the work piece. The work piece and the electrode are melted by the arc. Both molten piece of metal become one. Temperature of arc is about  $4000^{\circ}\text{C}$ . Electrodes used in arc welding are coated with a flux. This flux produces a gaseous shield around the molten metal. It prevents the reaction of the molten metal with oxygen and nitrogen in the atmosphere. The flux removes the impurities from the molten metal and form a slag. This slag gets deposited over the weld metal. This protects the weld seam from rapid cooling. Following Figure shows arc welding process.

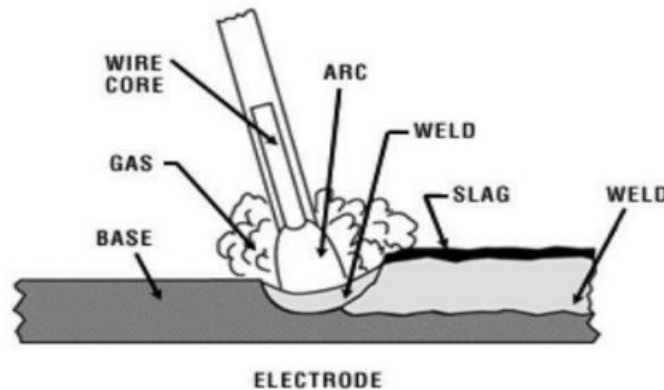
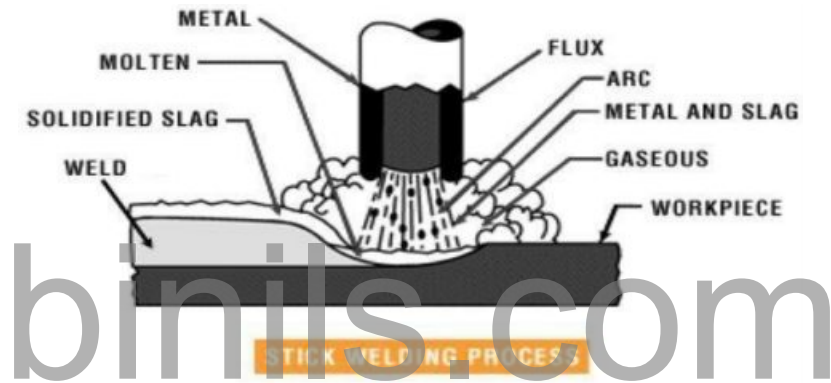



**Equipments:**

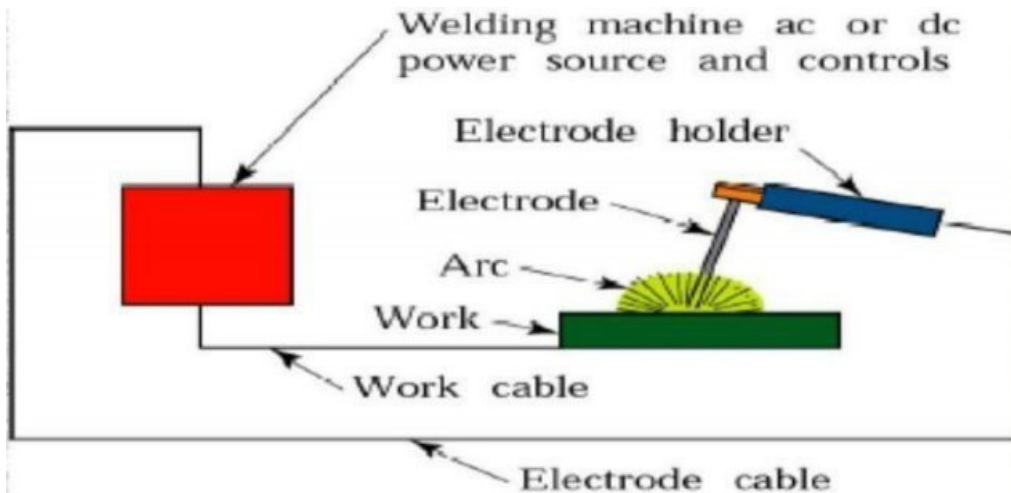

1. A welding generator (D.C.) or Transformer (A.C.)
2. Two cables- one for work and one for electrode
3. Electrode holder
4. Electrode
5. Protective shield
6. Gloves
7. Wire brush
8. Chipping hammer
9. Goggles

**Advantages**

1. Most efficient way to join metals
2. Lowest-cost joining method
3. Affords lighter weight through better utilization of materials
4. Joins all commercial metals
5. Provides design flexibility

**Limitations**

1. Manually applied, therefore high labour cost.
2. Need high energy causing danger
3. Not convenient for disassembly.
4. Defects are hard to detect at joints.

In this welding process produces joining of metals by heating them with an arc between a carbon electrode and the work-piece. This is the earliest of the arc-welding process but is not used nowadays in many applications because it replaced by twin carbon arc welding.

The carbon arc welding is just similar to metal arc welding. The difference of the both welding electrode are different . In this welding process, the electrode is having carbon material (Carbon rod) and it consist of negative pole and work piece as positive pole. The arc is produced to heat the metal to melt temperature. In this heat temperature in negative electrode as 2800°C and positive electrode as 3800°C.

The carbon electrode using as negative pole because of low temperature generated on the tip than work piece, and carbon electrode not fuse and mix up with the work piece. If happens, the weld will be rich in carbon, and consequently more brittle and consumed excessively. In this reason DC current used in carbon arc welding AC current not used in the welding because of fixed polarity can be maintained.

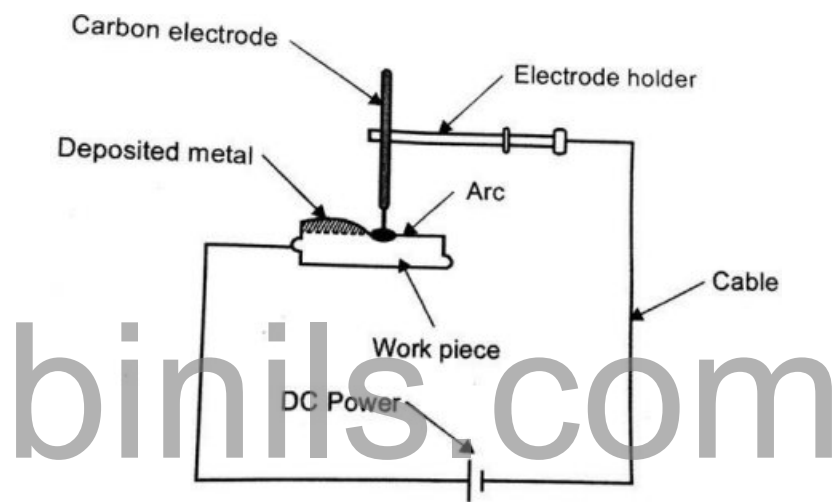

The weld is best for joint of two metal melted without of addition of filler metal.If need the filler metal in welding process, the welding rod as in oxyacetylene weld. Sometime, portion gas used in welding process because of protection of molten metal from atmospheric oxygen.

### Working Of Carbon Arc Welding

An electric arc is generated between the electrode and the parent metal. The heat generated due to the electric arc melts the base metal. After the solidification of the molten metal, the required weld is produced in the given region. You can vary the size of the electrode used in the process depending on the generated current. One of the variations of the CAW is twin carbon arc welding (TCAW). TCAW is a slightly different process than CAW.

In the TCAW, a special type of electrode is used. TCAW is designed in such a way that one carbon electrode is movable and can be touch with the other to produce the arc. During the twin carbon arc welding alternating current is used. Also, electrodes should be burned off at equal rates in the TCAW.

### Advantages of carbon arc welding:

Because of the separation of the heat source from the filler metal, better control of the heat input is possible.

1. Low distortion of the workpiece.
2. This process is easily automated.

### Limitations of carbon arc welding:

1. The major problem is the blowholes that are caused because of the turbulence associated with the DC power source.
2. This process is not suitable for the overhead or vertical welding position but very high mechanized welding speeds could be obtained by the process in the flat position.
3. A carbon of electrode contaminates weld material with carbides.
4. Unstable quality of the weld caused porosity.

#### Application of carbon arc welding:

1. Carbon arc welding is also used for joining galvanized steel. In this case, the bronze filler rod is added by placing it between the arc and the base metal.
2. The carbon arc welding process has been used almost entirely by the manual method of applying.
3. It is an all-position welding process.

#### SUBMERGED ARC WELDING

Submerged arc welding (SAW) process uses heat generated by an electric arc established between a bare consumable electrode wire and the work piece. Welding arc and the weld pool are completely submerged under cover of granular fusible and molten flux therefore it is called submerged arc welding.

During welding, granular flux is melted using heat generated by arc and forms cover of molten flux layer which in turn avoids spatter tendency and prevents accessibility of atmospheric gases to the arc zone and the weld pool.

Submerged SAW is known to be a high current (sometimes even greater 1000A) welding process that is mostly used for joining of heavy sections and thick plates as it offers deep penetration with high deposition rate and so high welding speed.

Complete cover of the molten flux around electrode tip and the welding pool during the actual welding operation produces weld joint without spatter and smoke.

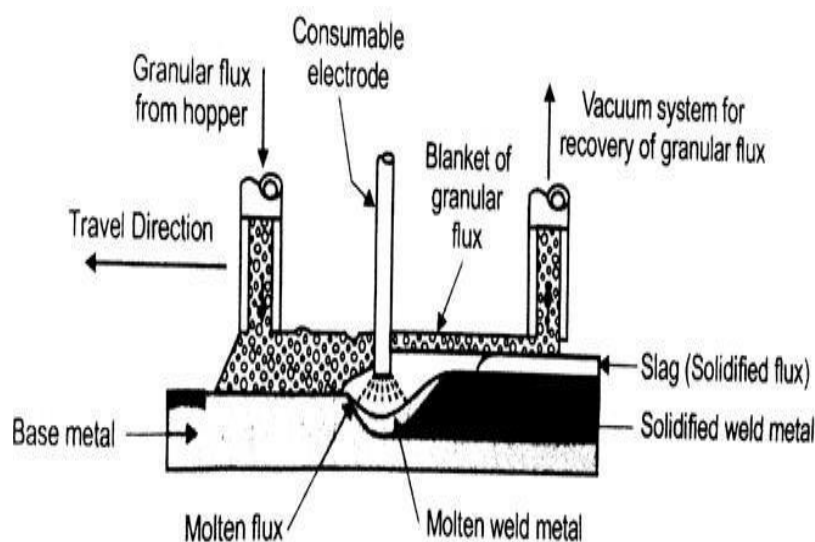

#### Working

A continuous (wire) electrode is being mechanically fed into the joint by powered drive rolls. The flux is fed from a hopper fixed to the welding head and a tube from hopper spreads the flux in a continuous manner in front of the Arc. When molten, the flux becomes conductive, and provides a current conducting path between the electrode and the work. A layer of granular flux deep enough to prevent the flash through, is being deposited in front of the arc. Electrical current which produces the arc is supplied to the electrode through the contact tube.

The current can be DC current up to 2000A, using single or multiple wires or strip of various alloys with electrode positive(reverse polarity) or with electrode negative(straight polarity)or alternating current(AC).The unfused flux and slag are removed from weld metal after solidification and may be used after screening The solidified slag may be collected, crushed, resized, and blended back into the new flux. SAW is adaptable to both semi-automatic and fully automatic operation

### **Advantages**

1. High productivity due to high deposition rate of the welding metal and capability of welding continuously without interruptions as electrode is fed from spool.
2. The process works under 100% duty cycle.
3. High depth of penetration allows welding of thick sections
4. Smooth weld bead is produced without stresses raisers as SAW is carried out without sparks, smoke and spatter.

### **Disadvantages**

1. Invisibility of welding arc during welding makes it difficult to ensure the location where weld metal is being deposited during welding
2. Therefore, it becomes mandatory to use an automatic device (like welding tractors) for accurate and guided movement of the welding arc in line with weld groove so that weld metal is deposited correctly along weld line only.
3. High heat input however is not considered good for welding of many steels as it leads to significant grain growth in weld and HAZ owing to low cooling rate experienced by them during welding
4. Restricted to the flat position for grooves
5. Slag removal required

### **Applications**

1. Used for Pressure Vessel Fabrication
2. Ship and barge building
3. Pipe manufacturing
4. Fabrication of structural members where long welds are required

It is an arc welding process wherein coalescence is produced by heating the job with an electric arc established between a continuously fed metal electrode and the job. No flux is used but the arc and molten metal are shielded by an inert gas, which may be argon, helium, carbon dioxide or a gas mixture.

### Principle of Operation (Semi Automatic Process)

Before igniting the arc, gas and water flow is checked. Proper current and wire feed speed is set and the electrical connections are ensured. The arc is struck by anyone of the two methods. In the first method current and shielding gas flow is switched on and the electrode is scratched against the job as usual practice for striking the arc.

In the second method, electrode is made to touch the job, is retracted and then moved forward to carry out welding; but before striking the arc, shielding gas, water and current is switched on. About 15 mm length of the electrode is projected from the torch before striking the arc. During welding, torch remains about 10-12 mm away from the job and arc length is kept between 1.5 to 4 mm. Arc length is maintained constant by using the principles of self adjusted arc, and self controlled arc in semi automatic (manually operated) and automatic welding sets respectively.

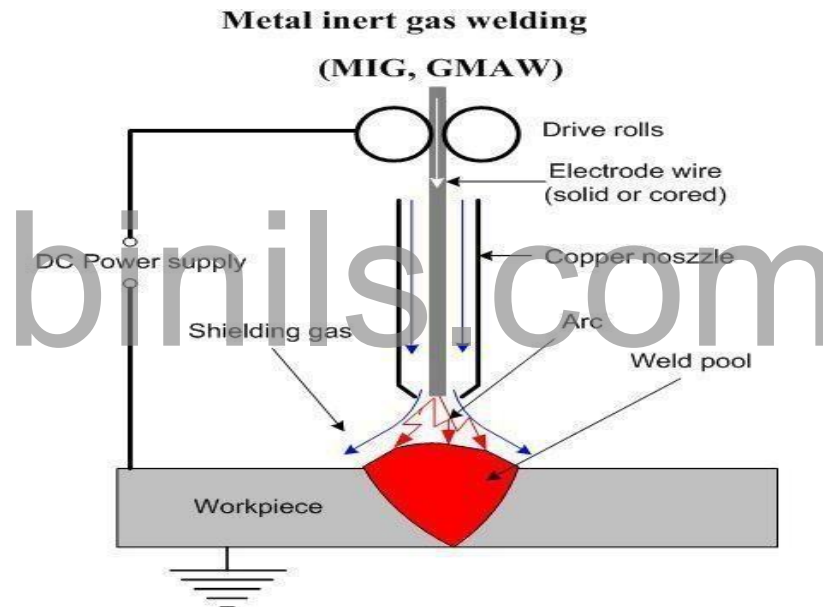

### Equipment

- (a) Welding power source and cables.
- (b) Welding torch and wire electrode coiled on a spool.
- (c) Wire feed mechanism and controls consisting of a pair of driving rolls, electric motor, etc.
- (d) Shielding gas cylinder, pressure regulator and flow meter.
- (e) Controls for switching on and off the current, electrode wire and inert gas.

Power sources possessing flat or drooping characteristics and rated at 400 Amps can be employed for MIG welding. Flat characteristic welding sources ensure a more constant arc length. The major types of power sources are DC generator or AC transformer with rectifier

DC electrode negative produces weld with shallow penetrations and thus can be used on thinner sections. DC electrode positive is preferred (when welding aluminium and magnesium) for its better arc cleaning action. DCRP also provides deeper penetration. AC is generally not recommended because of unequal burn off rates during negative and positive half cycles.

The welding torch energises the electrode, feeds the electrode and the shielding gas. The torch may be air cooled or water cooled. Torches working above 200 Amps are generally water cooled. The torch may have a straight or bent nozzle fitted at the end. A bent nozzle can be used for welding complicated shapes and intricate joints.

Wire feed mechanism may deliver electrode to the torch at a constant speed or at different speeds. The wire spool, in manually operated units, is mounted elsewhere to facilitate welding over a bigger area whereas in automatic machines, the wire spool is fixed on the same carriage over which the torch is mounted \*. The different diameters of the electrode wire are 0.8, 1.2, 1.6 mm, etc.

A standard wire spool may have from 1 to 15 kgs of wire. Steel electrodes are generally copper coated. As far as possible the chemical composition of the workpiece and that of the electrode should be similar; of course there may be the addition of deoxidizers. Electrodes are available for welding aluminium, magnesium, nickel, their alloys, carbon, low alloy and stainless steels, etc.

The function of a shielding gas is to protect the molten metal and the electrode end against atmospheric contamination. A number of shielding gases and gas mixtures like argon (for welding Al, Mg, Cu, Ni, Ti), helium (for welding Al, Mg, Cu), carbon dioxide (for welding mild steel), nitrogen (for welding copper), argon + (1-5%) Oxygen (for welding Al, low alloy and carbon steels, stainless steels), argon + CO<sub>2</sub> (for welding mild steel, low alloy and stainless steel), argon + helium + CO<sub>2</sub> (for welding austenitic stainless steels), argon + helium (for welding Al, Cu, Ni and their alloys), have been used in MIG welding.

Helium and CO<sub>2</sub> help increasing penetration whereas argon reduces spatter loss. Solenoid valves and relays may be incorporated in the system to put on and off gas, water and wire feed mechanism.

### Metals Welded

Base metals commonly welded by MIG welding are:

- (i) Carbon and low alloy steels.
- (ii) Stainless steels,
- (iii) Heat resisting alloys,
- (iv) Aluminium and its alloys,
- (v) Copper and its alloys (other than high zinc alloys),
- and (vi) Magnesium alloys.

### Advantages, Disadvantages and Applications of MIG OR GMAW Welding -

1. Because of continuously fed electrode, MIG welding process is much faster as compared to TIG or stick electrode welding.
2. It can produce joints with deep penetration.
3. Thick and thin, both types of workpieces can be welded effectively.
4. Large metal deposition rates are achieved by MIG welding process.
5. The process can be easily mechanized.
6. No flux is used. MIG welding produces smooth, neat, clean and spatter free welded surfaces which require no further cleaning. This helps reducing total welding cost.
7. Higher arc travel speeds associated with MIG welding reduce distortion considerably.

### Disadvantages



1. The process is slightly more complex as compared to TIG or stick electrode welding because a number of variables (like electrode stick out, torch angle, welding parameters, type and size of electrode, welding torch manipulation, etc.) are required to be controlled effectively to achieve good results.
2. Welding equipment is more complex, more costly and less portable.
3. Since air drafts may disperse the shielding gas, MIG welding may not work well in outdoor welding applications.
4. Weld metal cooling rates are higher than with the processes that deposit slag over the weld metal.

### Applications

1. The process can be used for the welding of carbon, silicon and low alloy steels, stainless steels, aluminium, magnesium, copper, nickel, and their alloys, titanium, etc.
2. for welding tool steels and dies.
3. for the manufacture of refrigerator parts.
4. MIG welding has been used successfully in industries like aircraft, automobile, pressure vessel, and ship building.

## TUNGSTEN INERT GAS WELDING (TIG) Gas tungsten arc welding

**Gas tungsten arc welding (GTAW)**, also known as **tungsten inert gas (TIG) welding**, is an arc welding process that uses a non consumable tungsten electrode to produce the weld. The weld area is protected from atmospheric contamination by a shielding gas (usually an inert gas such as argon), and a filler metal is normally used, though some welds, known as autogenous welds, do not require it. A constant-current welding power supply produces energy which is conducted across the arc through a column of highly ionized gas and metal vapours known as plasma.

### Operation

Manual gas tungsten arc welding is often considered the most difficult of all the welding processes commonly used in industry. Because the welder must maintain a short arc length, great care and skill are required to prevent contact between the electrode and the workpiece. Similar to torch welding, GTAW normally requires two hands, since most applications require that the welder manually feed a filler metal into the weld area with one hand while manipulating the welding torch in the other. However, some welds combining thin materials (known as autogenous or fusion welds) can be accomplished without filler metal; most notably edge, corner, and butt joints.

To strike the welding arc, a high frequency generator (similar to a Tesla coil) provides a spark; this spark is a conductive path for the welding current through the shielding gas and allows the arc to be initiated while the electrode and the workpiece are separated, typically about 1.5–3 mm (0.06–0.12 in) apart. This high voltage, high frequency burst can be damaging to some vehicle electrical systems and electronics, because induced voltages on vehicle wiring can also cause small conductive sparks in the vehicle wiring or within semiconductor packaging. Vehicle 12V power may conduct across these ionized paths, driven by the high-current 12V vehicle battery. These currents can be sufficiently destructive as to disable the vehicle, thus the warning to disconnect the battery power from both +12 and ground before using welding equipment on vehicles.

An alternate way to initiate the arc is the "scratch start". Scratching the electrode against the work with the power on also serves to strike an arc, in the same way as SMAW ("stick") arc welding. However, scratch starting can cause contamination of the weld and electrode. Some GTAW equipment is capable of a mode called "touch start" or "lift arc"; here the equipment reduces the voltage on the electrode to only a few volts, with a current limit of one or two amps (well below the



limit that causes metal to transfer and contamination of the weld or electrode). When the GTAW equipment detects that the electrode has left the surface and a spark is present, it immediately (within microseconds) increases power, converting the spark to a full arc.

Once the arc is struck, the welder moves the torch in a small circle to create a welding pool, the size of which depends on the size of the electrode and the amount of current. While maintaining a constant separation between the electrode and the workpiece, the operator then moves the torch back slightly and tilts it backward about 10–15 degrees from vertical. Filler metal is added manually to the front end of the weld pool as it is needed.

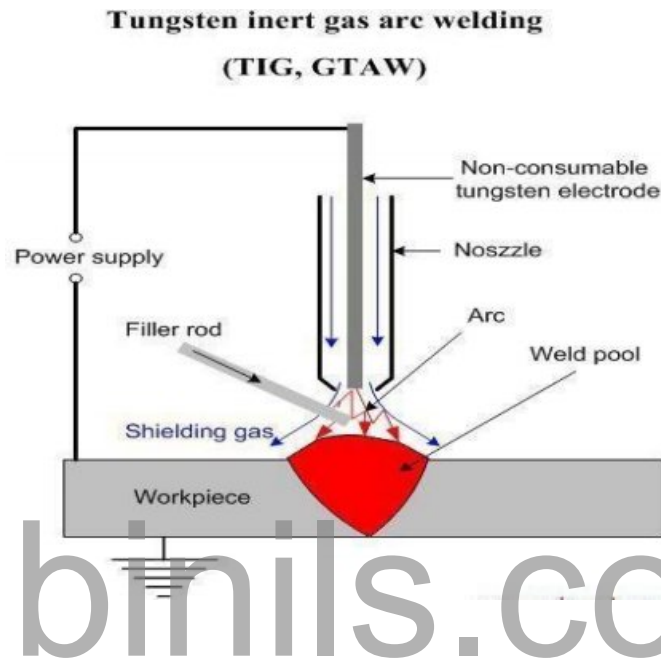

Welders often develop a technique of rapidly alternating between moving the torch forward (to advance the weld pool) and adding filler metal. The filler rod is withdrawn from the weld pool each time the electrode advances, but it is never removed from the gas shield to prevent oxidation of its surface and contamination of the weld. Filler rods composed of metals with low melting temperature, such as aluminum, require that the operator maintain some distance from the arc while staying inside the gas shield. If held too close to the arc, the filler rod can melt before it makes contact with the weld puddle. As the weld nears completion, the arc current is often gradually reduced to allow the weld crater to solidify and prevent the formation of crater cracks at the end of the weld.

### Equipment

The equipment required for the gas tungsten arc welding operation includes a welding torch utilizing a **non consumable** tungsten electrode, a constant-current welding power supply, and a shielding gas source.

### Welding torch

GTAW welding torches are designed for either automatic or manual operation and are equipped with cooling systems using air or water. The automatic and manual torches are similar in construction, but the manual torch has a handle while the automatic torch normally comes with a mounting rack. The angle between the centerline of the handle and the centerline of the tungsten electrode, known as the head angle, can be varied on some



*GTAW torch with various electrodes, cups, collets and gas diffusers*

manual torches according to the preference of the operator. Air cooling systems are most often used for low-current operations (up to about 200 A), while water cooling is required for high-current welding (up to about 600 A). The torches are connected with cables to the power supply and with hoses to the shielding gas source and where used, the water supply.

### **Power supply**

Gas tungsten arc welding uses a constant current power source, meaning that the current (and thus the heat) remains relatively constant, even if the arc distance and voltage change. This is important because most applications of GTAW are manual or semiautomatic, requiring that an operator hold the torch. Maintaining a suitably steady arc distance is difficult if a constant voltage power source is used instead, since it can cause dramatic heat variations and make welding more difficult.

The preferred polarity of the GTAW system depends largely on the type of metal being welded. Direct current with a negatively charged electrode (DCEN) is often employed when welding steels, nickel, titanium, and other metals. It can also be used in automatic GTA welding of aluminum or magnesium when helium is used as a shielding gas. The negatively charged electrode generates heat by emitting electrons which travel across the arc, causing thermal ionization of the shielding gas and increasing the temperature of the base material.

### **Electrode**

The electrode used in GTAW is made of tungsten or a tungsten alloy, because tungsten has the highest melting temperature among pure metals, at 3,422 °C (6,192 °F). As a result, the electrode is not consumed during welding, though some erosion (called burn-off) can occur. Electrodes can have either a clean finish or a ground finish—clean finish electrodes have been chemically cleaned, while ground finish electrodes have been ground to a uniform size and have a polished surface, making them optimal for heat conduction.

Pure tungsten electrodes (classified as WP or EWP) are general purpose and low cost electrodes. Cerium oxide (or ceria) as an alloying element improves arc stability and ease of starting while decreasing burn-off. Using an alloy of lanthanum oxide (or lanthana) has a similar effect. Thorium oxide (or thoria) alloy electrodes were designed for DC applications and can withstand somewhat higher temperatures while providing many of the benefits of other alloys. Filler metals are also used in nearly all applications of GTAW, the major exception being the welding of thin materials.

## Shielding gas

As with other welding processes such as gas metal arc welding, shielding gases are necessary in GTAW to protect the welding area from atmospheric gases such as nitrogen and oxygen, which can cause fusion defects, porosity, and weld metal embrittlement if they come in contact with the electrode, the arc, or the welding metal. The gas also transfers heat from the tungsten electrode to the metal, and it helps start and maintain a stable arc.

## Advantages of Tungsten Inert Gas Arc Welding (TIG, GTAW):

- ❑ Weld composition is close to that of the parent metal;
- ❑ High quality weld structure
- ❑ Slag removal is not required (no slag);
- ❑ Thermal distortions of work pieces are minimal due to concentration of heat in small zone.

## Disadvantages of Tungsten Inert Gas Arc Welding (TIG, GTAW):

- ❑ Low welding rate;
- ❑ Relatively expensive;
- ❑ Requires high level of operator's skill.

## Applications

GTAW is most commonly used to weld thin sections of stainless steel and non-ferrous metals such as aluminum, magnesium, and copper alloys. The process grants the operator greater control over the weld than competing procedures such as shielded metal arc welding and gas metal arc welding, allowing for stronger, higher quality welds. However, GTAW is comparatively more complex and difficult to master, and furthermore, it is significantly slower than most other welding techniques. A related process, plasma arc welding, uses a slightly different welding torch to create a more focused welding arc and as a result is often automated

Gas tungsten arc welding is most commonly used to weld stainless steel and nonferrous materials, such as aluminum and magnesium, but it can be applied to nearly all metals, with notable exceptions being lead and zinc. Its applications involving carbon steels are limited not because of process restrictions, but because of the existence of more economical steel welding techniques, such as gas metal arc welding and shielded metal arc welding. Furthermore, GTAW can be performed in a variety of other-than-flat positions, depending on the skill of the welder and the materials being welded.

## PLASMA ARC WELDING

**Plasma** is a gaseous mixture of positive ions, electrons and neutral gas molecules. Arc plasma is the temporary state of a gas. The gas gets ionized after the passage of electric current through it and it becomes a conductor of electricity. In ionized state gas atoms break into electrons (-) and ions (+) and the system contains a mixture of ions, electrons and highly excited atoms.

## Definition of Concept

Plasma arc welding is an arc welding process wherein coalescence is produced by the heat obtained from a constricted arc set up between a tungsten/alloy tungsten electrode and the water

cooled (constricting) nozzle (non transferred arc) or between a tungsten/alloy\* tungsten electrode and the job (transferred arc)

The process employs two inert gases, one forms the arc plasma and the second shields the arc plasma. Filler metal may or may not be added. Pressure, normally, is not employed.

### Principle of Operation

Plasma arc welding is a constricted arc process. The arc is constricted with the help of a water cooled small diameter nozzle which squeezes the arc, increases its pressure, temperature and heat intensity and thus improves arc stability, arc shape and heat transfer characteristics. Plasma arc welding process can be divided into two basic types:

- a) Non-transferred arc process. *Non-transferred arc process* produces plasma of relatively low energy density. It is used for welding of various metals and for plasma spraying (coating). Since the work piece in non-transferred plasma arc welding is not a part of electric circuit, the plasma arc torch may move from one work piece to other without extinguishing the arc. The arc is formed between the electrode (-) and the water cooled constricting nozzle (+). Arc plasma comes out of the nozzle as a flame. The arc is independent of the workpiece and the workpiece does not form a part of the electrical circuit.

Just as an arc flame (as in atomic hydrogen welding), it can be moved from one place to another and can be better controlled. The non transferred arc plasma possesses comparatively less energy density as compared to transferred arc plasma and it is employed for welding and in applications involving ceramics or metal plating (spraying).

High density metal coatings can be produced by this process. A non transferred arc is initiated by using a high frequency unit in the circuit

- b) Transferred arc process. *Transferred arc process* produces plasma jet of high energy density and may be used for high speed welding and cutting of Ceramics, steels, Aluminum alloys, Copper alloys, Titanium alloys, Nickel alloys. The arc is formed between the electrode (-) and the workpiece (+). In other words, arc is transferred from the electrode to the workpiece. A transferred arc possesses high energy density and plasma jet velocity. For this reason it is employed to cut and melt metals.

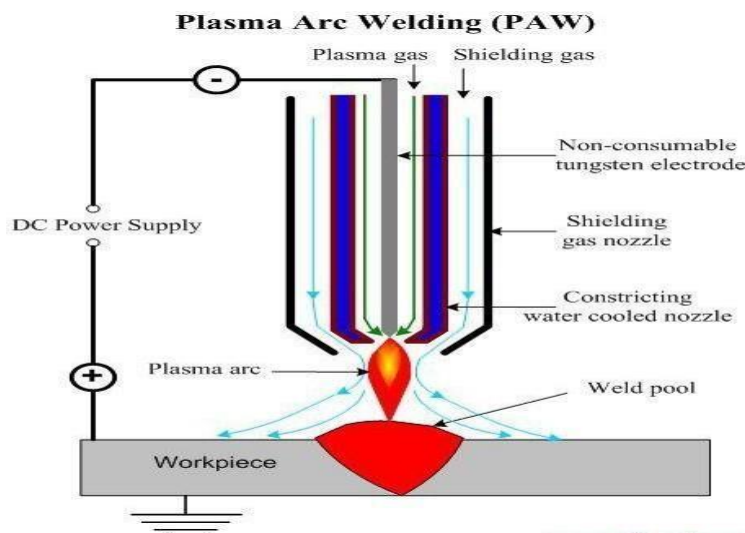

Besides carbon steels, this process can cut stainless steel and nonferrous metals also, where oxyacetylene torch does not succeed. Transferred arc can also be used for welding at high arc travel speeds. For initiating a transferred arc, a current limiting resistor is put in the circuit which permits a flow of about 50 amps between the nozzle and the electrode and a pilot arc is established between the electrode and the nozzle. As the pilot arc touches the job, main current starts flowing between electrode and job, thus igniting the transferred arc. The pilot arc initiating unit gets disconnected and pilot arc extinguishes as soon as the arc between the electrode and the job is started. The temperature of a constricted plasma arc may be of the order of 8000-25000°C

### **Plasma Arc Equipment -**

The equipments needed in plasma arc welding along with their functions are as follows:

1. Power Supply: A direct current power source (generator or rectifier) having drooping characteristics and open circuit voltage of 70 volts or above is suitable for plasma arc welding. Rectifiers are generally preferred over DC generators.

2. Working with helium as an inert gas needs open circuit voltage above 70 volts. This higher voltage can be obtained by series operation of two power sources; or the arc can be initiated with argon at normal open circuit voltage and then helium can be switched on.

Typical welding parameters for plasma arc welding are as follows:

Current 50 to 350 amps, voltage 27 to 31 volts, gas flow rates 2 to 40 liters/minute (lower range for orifice gas and higher range for outer shielding gas), DCSP is normally employed except for the welding of aluminium in which case water cooled copper anode and DCRP are preferred.

3. High frequency generator and current limiting resistors are used for arc ignition. Arc starting system may be separate or built in the system.

4. Plasma torch: It is either transferred arc or non transferred arc type. It is hand operated or mechanised. At present, almost all applications require automated system. The torch is water cooled to increase the life of the nozzle and the electrode. The size and the type of nozzle tip are selected depending upon the metal to be welded, weld shape and desired penetration height.

. Shielding gases. Two inert gases or gas mixtures are employed. The orifice gas at lower pressure and flow rates forms the arc plasma. The pressure of the orifice gas is intentionally kept low to avoid weld metal turbulence, but this low pressure is not able to provide proper shielding of the weld pool.

To have suitable shielding protection, same or another inert gas is sent through the outer shielding ring of the torch at comparatively higher flow rates. Most of the materials can be welded with argon, helium, argon + hydrogen and argon + helium, as inert gases or gas mixtures. Argon is very commonly used. Helium is preferred where a broad heat input pattern and flatter cover pass is desired.

A mixture of argon and hydrogen supplies heat energy higher than when only argon is used and thus permits higher arc travel speeds and is preferred for welding some nickel base alloys and stainless steels.

For cutting purposes a mixture of argon and hydrogen (10-30%) or that of nitrogen and hydrogen may be used. Hydrogen, because of its dissociation into atomic form and thereafter recombination generates temperatures above those attained by using argon or helium alone.

5. Voltage control: Voltage control is required in contour welding. In normal key hole welding a variation in arc length up to 1.5 mm does not effect weld bead penetration or bead shape to any significant extent and thus a voltage control is not considered essential.

6. Current and gas decay control: It is necessary to close the keyhole properly while terminating the weld in the structure.

#### **Base Metal Welded**

Base metals welded by Plasma arc welding are

- (i) Carbon and low alloy steels
- (ii) Stainless steels
- (iii) Copper alloys
- (iv) Nickel and cobalt base alloys
- (v) Titanium alloys
- (vi) Aluminium alloys.

Comparison between Plasma Arc Welding and TIG Welding -

binils.com



### Plasma Arc Welding

1. It employs a constricted arc.
2. It uses two inert gases, one plasma gas and another inert gas to shield plasma and weld pool.
3. To protect atmospheric contamination of  
Under bead a set up as may be employed.
4. Electrode remains within the nozzle, therefore, contamination are nil.
5. Improved input heat distribution in the job as compared to TIG welding.
6. Filler metal requirements are less as compared to TIG welding because lesser number of runs is needed to complete the weld.
7. It permits faster metal deposition rates and higher arc travel speeds as compared to TIG welding.
8. Plasma arc welding is less sensitive to joint mismatch and small variations in arc length as compared to TIG welding.

### TIG welding

1. It uses a non-constricted arc.
2. It uses only one gas which forms plasma as well as shields the arc and molten weld pool.
3. No such arrangement is employed of tungsten inclusion and electrode inclusion and electrode contamination are there if carelessly welded.

binils.com



## Advantages Disadvantages and Applications of Plasma Arc Welding –

### Advantages

Some of the advantages of plasma arc welding in addition to those mentioned under section 4.11.9 are listed below:

1. Stability of arc.
2. Uniform penetration.
3. Simplified fixtures.
4. Rewelding of the root of the joint saved.
5. It is possible to produce fully penetrated keyhole welds on pieces upto and about 6 mm thick with square butt joint.
6. Excellent weld quality.
7. Plasma arc welding can produce radiographic quality welds at high speeds.
8. It can weld steel pieces up to about one half inch thick; square butt joint in single run with no filler metal addition.

### Disadvantages

1. Infrared and ultraviolet radiations necessitate special protection devices.
2. Welders need ear plugs because of unpleasant, disturbing and damaging noise.
3. More chances of electrical hazards are associated with this process.
4. The process is limited to metal thickness of 25 mm and lower for butt welds.
5. Plasma arc welding process and equipment are more complicated and require greater knowledge on the part of the welder as compared to TIG welding.
6. Inert gas consumption is high

### Applications

Plasma arc welding finds applications as follows:

1. Single runs autogenous and multi-run circumferential pipe welding.
2. in tube mill applications.
3. Welding cryogenic, aerospace and high temperature corrosion resistant alloys.
4. Nuclear submarine pipe system (non-nuclear sections, sub assemblies).
5. Welding steel rocket motor cases.
6. Welding of stainless steel tubes (thickness 2.6 to 6.3 mm).
7. Welding of carbon steel, stainless steel, nickel, copper, brass, monel, inconel, aluminium, titanium, etc.
8. Welding titanium plates up to 8 mm thickness.
9. Welding nickel and high nickel alloys.
10. for melting, high melting point metals.
11. Plasma torch can be applied to spraying, welding and cutting of difficult to cut metals and alloys

## ELECTRO SLAG WELDING PROCESS

Electroslag Welding Process is a welding process in which the job is welded through the molten slag covering which is a result of high quantity of heat which is generated by the circulation of electric current through the electrode and the job.

### Principle:

Electroslag welding process works on the principle of heat generation due to arc and electric resistance. Arc is made between welding electrode and the workpiece which starts melting

the filler metal to fill the filler cavity. Now the heat is produced due to electric resistance when the current passes through the surface. The heat further starts melting the filler metal which is continuously fed from the roller. This filler wire melts and fills the weld and makes it a strong joint.

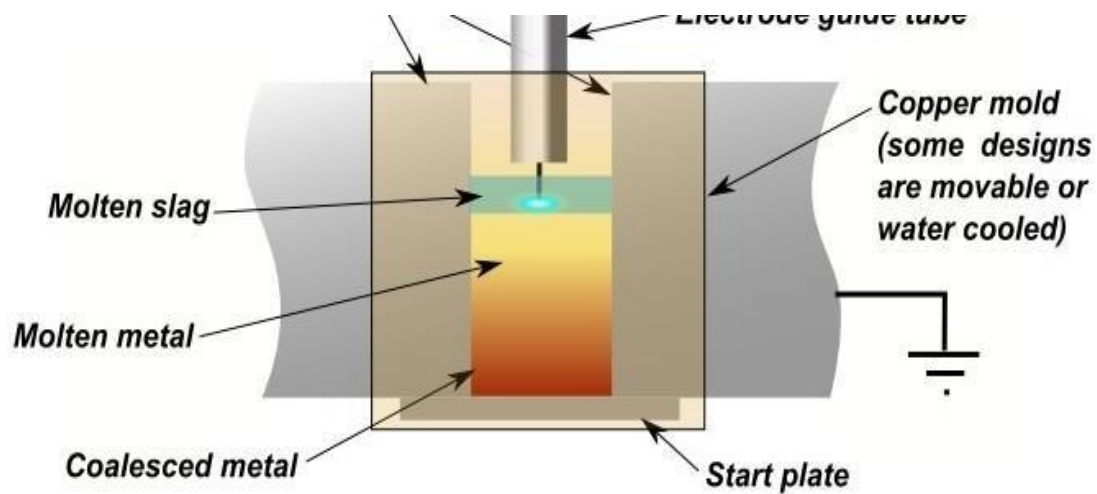

### Working of Electroslag Welding

- ⌞ Firstly current flows from welding electrode to base plate. This establishes an arc between electrode and base plate which heats the flux. This heat which is produced during arc formation results in melting the filler metal and deposits into the weld cavity.
- ⌞ Now the cooled copper shoe starts its function of solidifying the filler metal into weld cavity. This is done to avoid flowing of weld metal outside.
- ⌞ As the filler metal solidifies into weld cavity, the current flows through it. Then it generates heat due to electric resistance. This heat is further used to continue the melting of the filler metal into weld cavity. Which means that heat is regenerated, which results in less waste of heat or energy.
- ⌞ Roller arrangement continuously provides the filler metal.
- ⌞ During welding of the metals both copper shoe and feed mechanism moves upward until the whole cavity is formed.
- ⌞ This will create a strong joint in single one pass. The single or multi-pass weld is used according to plate thickness.

#### Advantages:

1. Cooling rate is very low so there is no problem of cold cracking.
2. There is no problem of slag inclusion or porosity.
3. The process is semi-automatic and faster.
4. Heavier section can be welded in single pass.
5. High productivity can be achieved.
6. Low cost for joint preparation.

**Disadvantages:**

1. Too high heat input to base.
2. High temperature of welding needs cooling arrangement.
3. Slow rate of cooling give columnar grain in weld.
4. When the heat input is very high then the weld quality can be poor, including low toughness caused by the coarse grains in the fusion zone and the heat-affected zone.
5. In Electroslag welding, it has some tendency towards hot cracking and notch sensitivity in the heat affected zone.
6. It is restricted to vertical position welding, because of large molten metal pools and slag.
7. It is difficult to close cylindrical welds
8. It tends to produce large grain sizes..
9. If you are creating joints below 60 mm than Submerged Arc Welding (SAW) is more economical than electroslag welding process.

**Application:**

1. It is used in heavy industries where plate thickness is up to 80 mm to be joined.
2. Welding of thick walled large diameter pipes is done by this welding process.
3. Welding of storage tanks is done by it.
4. It is used to construct big and thick parts of ships.

binils.com