

## SYLLABUS

### **FUNDAMENTALS OF INSTRUMENTATION**

**PAGE NO: 4 - 13**

Definition – Measurement, Instrument, Instrumentation system. Generalized Functional block diagram of an Instrumentation system – Examples – Bourdon tube pressure gauge, Pressure Thermometer. Definition – Standards, Primary, Secondary and Working Standards –Definition – Error, True value, Correction, Calibration, Zero error, Backlash error- Classification of errors – Gross error, Systematic error, Random error. Statistical analysis of test data – Arithmetic mean, Deviation, Standard Deviation, Variance, Simple problems.

### **PERFORMANCE CHARACTERISTICS OF INSTRUMENTS**

**PAGE NO: 14 - 20**

Static characteristics – Range, Span, Accuracy, Precision, Significant of figure, Range of doubt, Dead time, Dead zone, Hysteresis, Threshold, Resolution, Sensitivity, Linearity, Reproducibility, Stability, Loading effect, Input impedance and Output impedance. Dynamic characteristics – Speed of response, Measuring lag, Fidelity and Dynamic error. Standard Test input signals - Dynamic response – Steady state and Transient response.

### **TRANSDUCERS AND SENSORS**

**PAGE NO: 21 - 32**

Transducer – Definition, classification – Primary and Secondary transducer, Active and Passive transducer, Analog and Digital transducer, Transducer and Inverse Transducer (with one example for each classification). Characteristics of transducer – Input characteristics, Output characteristics and transducer Response. Factors to be considered in the selecting of Transducers. Electrical Transducer- Advantages of electrical Transducer over Mechanical Transducer. Sensors – Pressure Sensor, Proximity and Displacement sensor, Magnetic sensor, Bio sensor, Hall-effect sensor, Optical sensor.

### **MECHANICAL TRANSDUCER**

**PAGE NO: 33 - 41**

Definition- Mechanical pressure transducer - Elastic element – Bourdon tube, Bellows, Diaphragms. Manometers – U Tube manometer, Well type manometer, Barometer, Inclined tube manometer, Ring balance manometer, Micro manometer, manometric fluids-Construction, Principle, Working and Applications only –Thermal detectors – Liquid in glass thermometer, Filled system thermometer, Bi-metallic thermometer- Construction, Principle, Working and Applications only. Hydro-pneumatic elements – Venturi and Orifice - Construction, Principle, Working and Applications only.

### **ELECTRICAL TRANSDUCER**

**PAGE NO: 42 - 59**

Definition- Resistive Transducer-Potentiometer–types, Piezo-Resistive effect- Strain gauge – types – bonded, unbonded and semiconductor. Resistance Temperature Detector - Thermocouple, Thermistor, Thermo-diodes and transistors – Construction, Principle, Working and Applications only. Variable Inductance Transducer - LVDT, Variable capacitance transducer - Construction, Principle, Working and Applications only. Piezo-electric Transducer – Piezo electric effect, materials, Modes of operation, Properties of Piezo electric crystals, Equivalent circuit – Applications.

**TEXT BOOK:**

1. A course in Electrical and Electronic measurement and Instrumentation by A.K.Shawney, Dhanpat Rai & co.,Reprint 2010.

**REFERENCE BOOKS**

1. HERMAN. K. P NEUBERT, Instrument transducers, An Introduction to their performance and design, Oxford University Press, 2ndEdition.
2. A. K .SHAWNEY, PUNEET SHAWNEY, A course in Mechanical measurement and Instrumentation, Dhanpat Rai & co, 12thEdition, 2001 – 2002.
3. D. S. KUMAR, Mechanical measurements & control, Metropolitan Book co Pvt. Ltd, 3rd Edition 1989.
4. S.K. SINGH, Industrial Instrumentation & control, Tata Mc Graw Hill publishing company Ltd. 13thEdition 1997.
5. C. NAKRA, K. K. CHAUDRY, Instrumentation Measurement and Analysis, 2ndEdition, Tata McGraw Hill Publishing company.

[www.binils.com](http://www.binils.com)

**GOVERNMENT OF TAMILNADU  
DIRECTORATE OF TECHNICAL EDUCATION  
CHENNAI – 600 025**

**STATE PROJECT COORDINATION UNIT**

**Diploma in Instrumentation and Control Engineering**

**Course Code: 1042**

**M – Scheme**

**e-TEXTBOOK**

**on**

**Basics Of Instrumentation**

**for**

**III Semester DICE**

**Convener for ICE Discipline:**

**Dr.S.Rajakumari,**  
Head of Department/ECE,  
Dr.Dharmambal Govt. Polytechnic College for Women,  
Tharamani, Chennai - 600 113

**Team Members for Industrial Instrumentation:**

**Mr.R.Selva kumar**  
Lecturer / ICE,  
135, GOVERNMENT POLYTECHNIC COLLEGE,  
CHEYYAR

**Tmt.T.Suganya**  
Lecturer / ICE,  
176, Govt Polytechnic College for women,  
Coimbatore – 641 044

**Validated By**

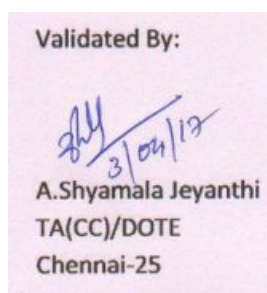

### **Preamble**

This e-book is prepared to give basic facts about instrumentation. It is divided into five units with the following topics.

The first unit deals with measurement, instruments, instrumentation system , examples for instrumentation system, standard and its types, errors and its classification and statistical analysis of data.

The second unit is about the performance characteristics of instruments , its dynamic response and standard test input signals.

The third unit gives the classification of transducers with examples, factors for selecting transducer, characteristics of transducer, about electrical transducer and sensor.

The fourth unit is about mechanical transducers like pressure transducer, thermal detectors and hydro pneumatic elements.

The fifth unit deals with electrical transducers – resistive, inductive, and capacitive transducer and also peizo electric transducer.

[www.binils.com](http://www.binils.com)

## UNIT-I FUNDAMENTALS OF INSTRUMENTATION

### 1.1 Definition

#### 1. Measurement:

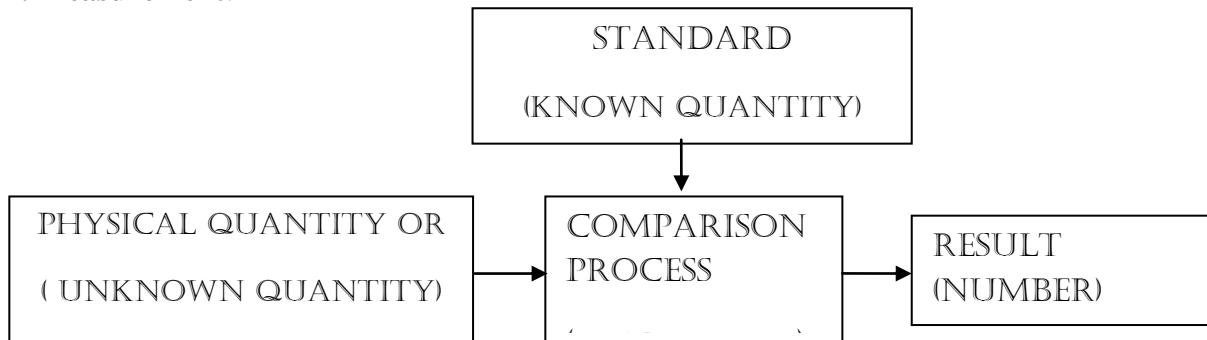

Fig.1.1

A measurement is a process of comparing a physical quantity with a standard unit and the physical quantity is converted to a number.

#### 2. Instrument:

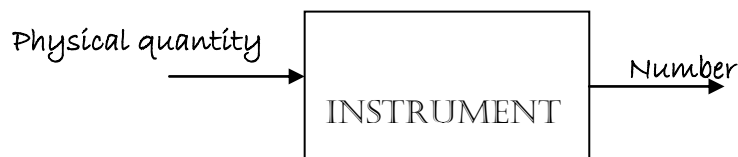

Fig 1.2

It is a physical means used to determine the physical quantity.

#### 3. Instrumentation system:

The system that deals with techniques used for measurement, the measuring devices used and problems that are associated with the techniques used for measurement.

### 1.2.Generalized functional block diagram of an Instrumentation system

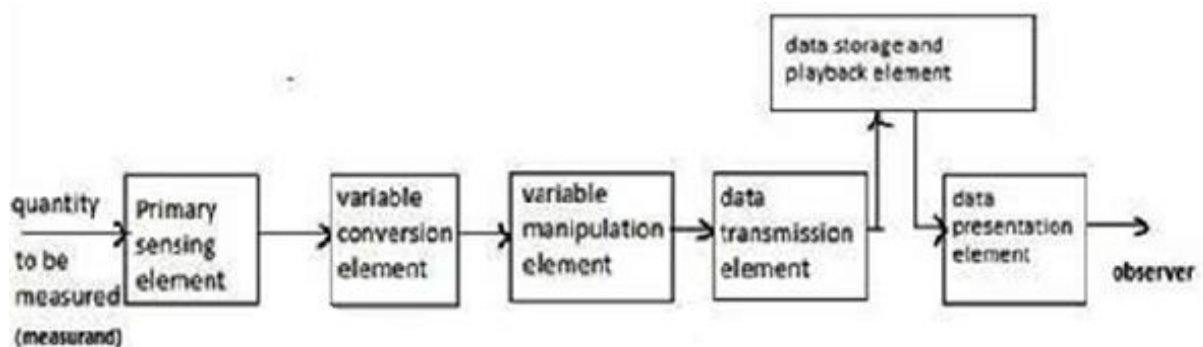

Fig.1.3

Functional blocks:

Measured Medium:

Solid, liquid, gas, fluid are the measured medium.

Measured Quantity or Measurand:

Pressure, Temperature, Velocity, Stress are some of the measured quantity

Primary Sensing Element:

The sensor or deductor is the primary sensing element. The *primary sensing element* senses the measured quantity from the measured medium. The measured quantity is converted to physical variable. Ex. Thermometer

Variable Conversion Element:

The instrument that converts the physical variable or nonelectrical to electronic signals is called a *variable-conversion element or transducer*. Transducers convert signals of various physical forms to electronic signals and electronic signals to physical forms.

Ex: current → Voltage; Pressure → Displacement; Strain → Charge (Voltage)

Variable Manipulation Element:

Manipulation -- a change in numerical value according to some definite rule but the physical nature of the variable is to be preserved. An element that performs such a function is called a *variable-manipulation element*

Ex. Speaker.-Conversion of a change in resistance to a variation in voltage or current, amplification, attenuation, Filtering, Analog/Digital conversion.

Data Transmission:

An element which transmits data from one element to another, when they are physically separated is called a *data-transmission element*. Ex. Wire, fiber optic cable, shaft and bearing assembly, telemetry system for transmitting signals from satellites to ground equipment by radio.

Data Storage:

An element that is used to store the data from variable manipulation element.

Ex. Computer, Storage Oscilloscope, Chart / Pen, Printer for printing, VDU for displaying , Computer for storage.

Data Presentation:

If the information about the measured quantity is to be communicated for monitoring, control or analysis purposes it must be put into a recognizable form. The element that performs this "translation" function - *data-presentation element*. This function includes the simple indication of a pointer moving over a scale and the recording of a pen moving over a chart.

Indication and recording also may be performed in discrete increments.

Ex: CRT, oscilloscope, dial indicator, pointer and scale, digital display.

**Example -1:- Bourdon tube pressure gauge.**

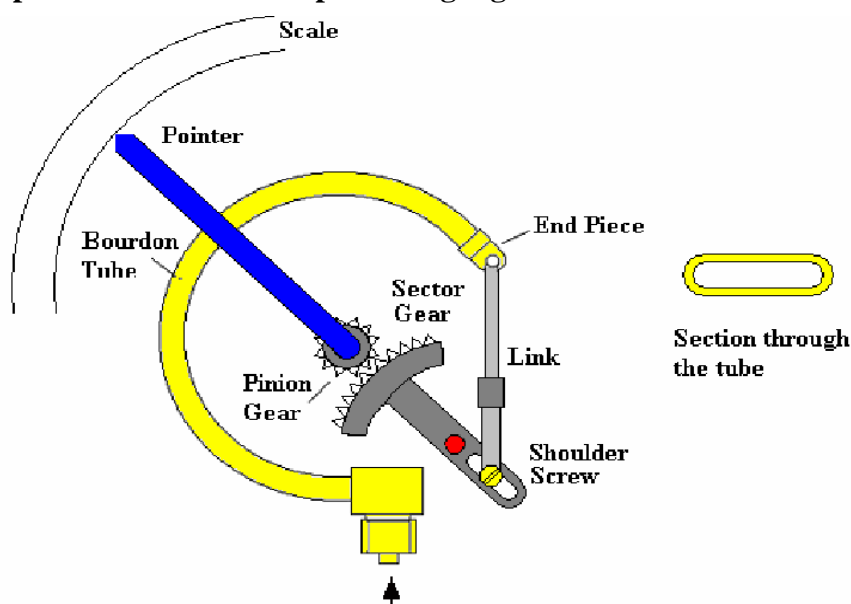

Fig.1.4a

- The bourdon tube senses the input quantity - pressure.
- Due to the pressure, the closed end of the bourdon tube is displaced.
- Thus the pressure is converted into a small displacement.
- Thus the bourdon tube act as the primary sensing element and as a variable conversion element.
- The closed end of the bourdon tube is connected through mechanical linkage to a gearing arrangement.
- The mechanical linkage thus acts as a data transmission element.
- The gearing arrangement amplifies the small displacement and makes the pointer to rotate through a large scale.
- The gearing arrangement acts as a data manipulation element.
- The pointer-scale on the gauge acts as a data presentation element and the pressure measured is displayed.

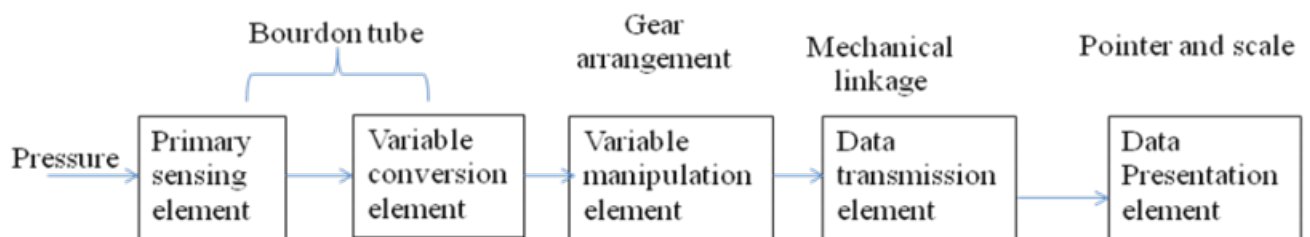

Fig.1.4b

**Example-2:- Pressure thermometer.**

- The liquid-or-gas-filled temperature bulb senses the temperature change of the fluid.
- This temperature change of the fluid results in a pressure change within the bulb because of the constrained thermal expansion of the liquid or gas filled in the bulb.
- Thus the temperature bulb acts as a primary sensing element and also as variable – conversion element due to the conversion of temperature to pressure.
- This pressure is transmitted to the Bourdon-tube through the capillary tube.
- The capillary tube acts as a data –transmission element.
- As the bourdon tube converts the pressure to displacement, it also act as variable – conversion element.
- The displacement is manipulated by the linkage and gearing arrangement to give a larger pointer motion.
- So variable –manipulation element is the linkage and gearing arrangement.
- The pointer and scale indicate the temperature, thus serving as data presentation element.

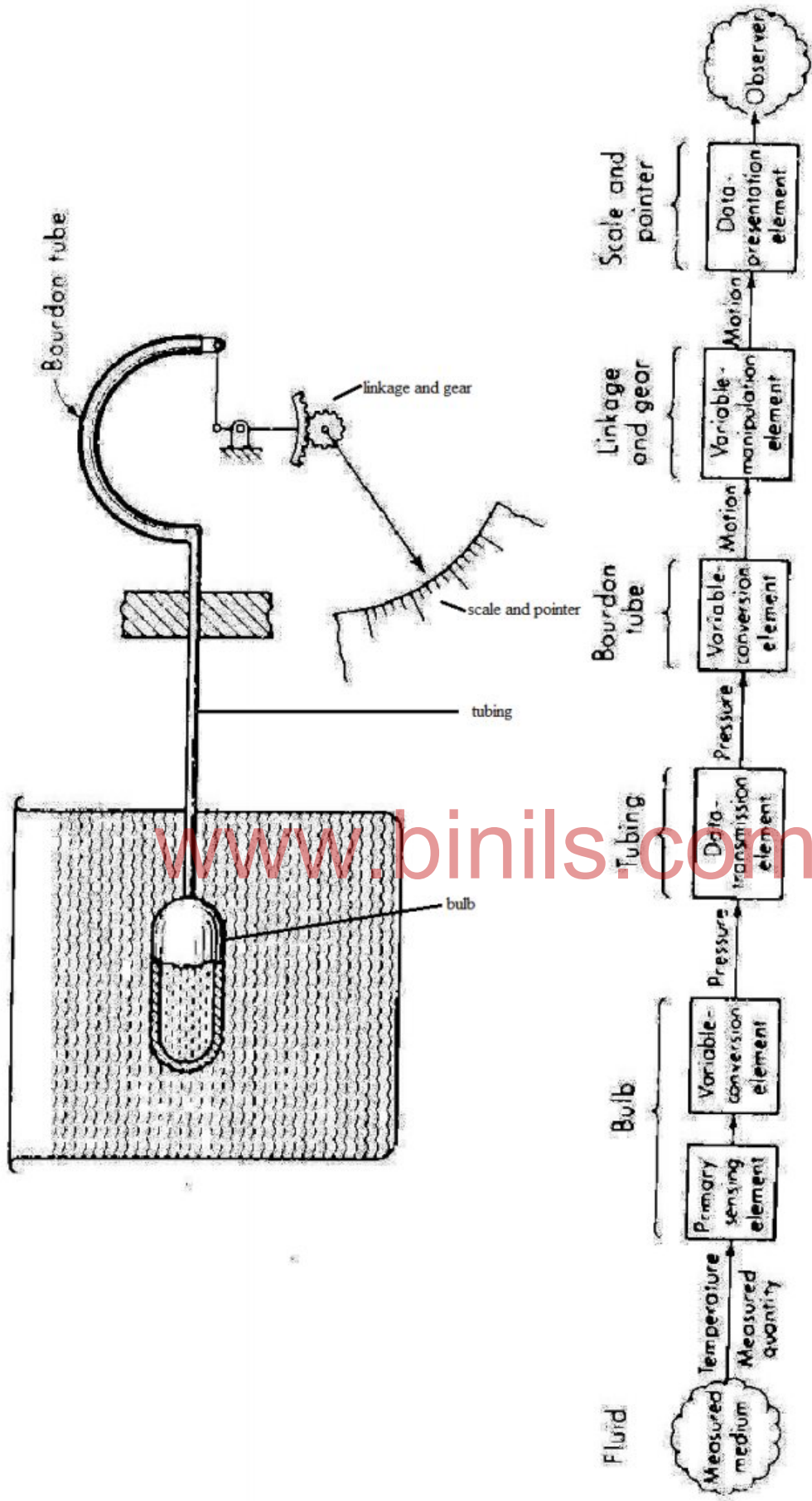

Fig.1.5



### 1.3. Definition:

**Standard: Standards** are the fundamental reference for a system of weights and measures, against which all other measuring devices are compared.

#### **Classification of standards:**

Standards are classified into four levels. They are,

1. International standards
2. Primary standards
3. Secondary standards
4. Working standards

#### **International standards**

1. They are defined by international agreement, and are maintained at the International Bureau of Weight and Measure in France.
2. These are as accurate as it is scientifically possible to achieve.
3. They may be used for comparison with primary standard, but cannot be used for any other application.

#### **Primary Standard**

1. They are maintained at institutions in various countries around the world, such as the National Bureau of Standards in New Delhi, India.
2. These are as accurate as it is scientifically possible to achieve.
3. They are also constructed for the greatest possible accuracy, and their main function is checking the accuracy of secondary standard.

#### **Secondary standard**

1. Secondary standards are more accurate than working standard
2. Used throughout industry for checking working standards and for calibrating high accuracy equipment
3. To periodically check and to maintain the primary standards at the institutions.
4. To verify the accuracy of working standards

#### **Working Standard**

1. The working standards are the principal tools of a measurement laboratory.
2. They are used to check and calibrate general laboratory instrument for accuracy and performance
3. To perform comparison in industrial measurement application.

### **1.4. Error (e)**

It is defined as the difference between the true value and the measured value.

$$\text{Error} = \text{measured value} - \text{true value.}$$

$$e = A_m - A_t$$

### **1.5. True value ( $A_t$ ):**

It is the actual standard value of a physical quantity .

### **1.6. Correction factor (c):**

It is defined as difference between the measured value and the true value.

$$c = -e$$

#### **Problem:**

A meter reads 127.5 v and the true value is 127.43 .Determine a) error b) correction

$$\begin{array}{lcl} \text{Error} & e & = A_m - A_t \\ & & = 127.5 - 127.43 & = 0.07 \end{array}$$

$$\begin{array}{lcl} \text{Correction} & c & = -e \\ & & = -0.07 \end{array}$$

## 1.7. Calibration

It is the comparison of a device with unknown accuracy to a device with known accurate standard to eliminate any variation in the device under test.

### 1. Zero error

1. A zero error arises when the measuring instrument does not start from exactly zero.
2. The zero error can be positive or negative.

**NEGATIVE ZERO ERROR:** The pointer of a meter does not place on zero but shows a negative value when no input is given.

**POSITIVE ZERO ERROR:** The pointer of the ammeter does not place on zero but shows a positive value when no input is given.

3. **NO ZERO ERROR:** The pointer of a meter place on zero when no input is given.



Fig.1.6

### 2. Backlash error

It is defined as the amount of lost motion due to clearance or slackness when movement is reversed and contact is re-established.

Sometimes due to wear and tear of the screw threads, it is observed that reversing the direction of rotation of the thimble, the tip of the screw does not start moving in the opposite direction immediately, but remains stationary for a part of rotation. This is back lash error.

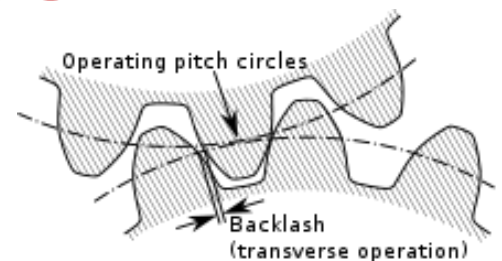

Fig.1.7

### 1.8. Classification of errors:

Generally errors are classified mainly into three categories as follows:

- (a) Gross errors
- (b) Systematic errors
- (c) Random errors

#### (a) Gross Errors

These errors are due to the mistakes done by the experimenters or observers like

- mistake in using instruments,
- recording data
- calculating measurement results.

For example: A person may read a pressure gage indicating  $1.01 \text{ N/m}^2$  as  $1.10 \text{ N/m}^2$ .

Someone may have a bad habit of memorizing data at a time of reading and writing a number of data together at later time. This may cause error in the data. Errors may be made in calculating

the final results also. Care must be taken to avoid this error. Experiments must be repeated with different persons.

### (b) Systematic Errors

Systematic error is a type of error that deviates by a fixed amount from the true value of measurement.

The types of systematic errors are:

- Constructional Error or instrumental error
- Environmental error
- Observational error

Constructional Error or instrumental error:

This error is due to construction of instrument ie. Due to the division of the scale not being uniform and clear or if the pointer is not fine and straight.

This type of error may also arise when the instrument is wrongly used by the experimenter.

Two types of instrumental error:

1. Offset or zero setting error in which the instrument does not read zero when the quantity to be measured is zero.
2. Multiplier or scale factor error in which the instrument consistently reads changes in the quantity to be measured greater or less than the actual changes.

Environmental error:

This type of error arises due to conditions external to instrument. External condition includes temperature, pressure, humidity or it may include external magnetic field. Following are the steps that one must follow in order to minimize the environmental errors:

(A) Try to maintain the temperature and humidity of the laboratory constant by making some arrangements.

(B) Ensure that there should not be any external magnetic or electrostatic field around the instrument.

Observational error:

Parallax error is the change in the apparent position of an object when the position of the observer changes. In the pointer there may be parallax error in reading. A parallax error in a meter reading.

(c) Random Errors or statistical error

Random errors are errors in measurement that lead to measurable values being inconsistent when repeated measures of a constant attribute or quantity are taken. These changes may occur in the measuring instruments or in the environmental conditions.

Examples of causes of random errors are:

- electronic noise in the circuit of an electrical instrument,
- irregular changes in the heat loss rate from a solar collector due to changes in the wind.

Statistical methods may be used to analyze the data having random error.

### 1.9. Statistical analysis of test data

Statistical analysis is a process of collecting, processing and presenting test data.

A set of N data points are collected by two forms of test:

- 1) Multiple sample test

In this test, repeated measurement of a given quantity are done using different methods of measurement, different instruments, different observers and the data is analysed by

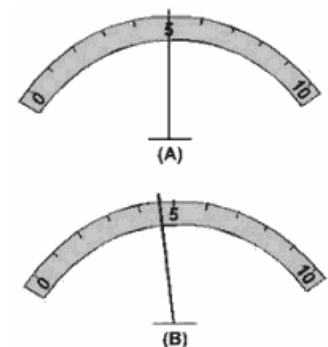

Fig.1.8

## HISTOGRAM

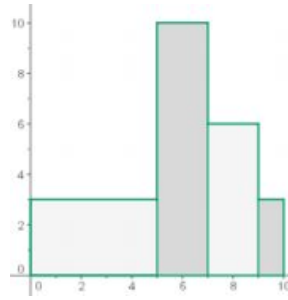

Fig.1.9

### 2) Single Sample test:

In this test repeated measurement of a given quantity are done different time but under same condition.

#### Arithmetic mean:

The arithmetic mean is the average value of the distribution.

To obtain the value of the arithmetic mean, calculate the sum of the data and divide the result by the total number of data.

$$\bar{x} = \frac{\sum_{i=1}^n x_i}{N}$$

$$\bar{x} = \frac{x_1 + x_2 + x_3 + \dots + x_n}{N}$$

where  $\bar{x}$  = arithmetic mean.

$x_1, x_2, x_3, \dots, x_n$  = data

$N$  = total number of data.

#### Deviation:

Deviation is the absolute difference between each value of the variable and the arithmetic mean.

$$D = |x - \bar{x}|$$

Average deviation

The mean deviation or average deviation is the arithmetic mean of the absolute deviations and is denoted by  $D_{\bar{x}}$ .

$$D_{\bar{x}} = \frac{|x_1 - \bar{x}| + |x_2 - \bar{x}| + \dots + |x_n - \bar{x}|}{N}$$

$$D_{\bar{x}} = \frac{\sum_{i=1}^n |x_i - \bar{x}|}{N}$$

#### Standard deviation :

The standard deviation is the root mean square (RMS) deviation of the values from their arithmetic mean. The standard deviation is the square root of the variance. The standard deviation is represented by  $\sigma$ .

$$\sigma = \sqrt{\frac{(x_1 - \bar{x})^2 + (x_2 - \bar{x})^2 + \dots + (x_n - \bar{x})^2}{N}}$$

$$\sigma = \sqrt{\frac{\sum_{i=1}^n (x_i - \bar{x})^2}{N}}$$

**Variance :**

The variance is the arithmetic mean of the squared deviations from the mean. The variance is represented by square of the standard deviation ( $\sigma^2$ ).

$$\sigma^2 = \frac{(x_1 - \bar{x})^2 + (x_2 - \bar{x})^2 + \dots + (x_n - \bar{x})^2}{N}$$

$$\sigma^2 = \frac{\sum_{i=1}^n (x_i - \bar{x})^2}{N}$$

Simple Problems

1. The weight of six children can be expressed by the following values: 84, 91, 72, 68, 87 and 78 pounds. Find the mean.

$$\bar{x} = \frac{x_1 + x_2 + x_3 + \dots + x_n}{N}$$

$$\bar{x} = \frac{84 + 91 + 72 + 68 + 87 + 78}{6} = 80 \text{ pounds}$$

2. The heights are: 600mm, 470mm, 170mm, 430mm and 300mm. Find out the Mean, the Variance, and the Standard Deviation.

$$\bar{x} = \frac{x_1 + x_2 + x_3 + \dots + x_n}{N}$$

$$\text{Mean} = \frac{600 + 470 + 170 + 430 + 300}{5} = \frac{1970}{5} = 394$$

so the mean (average) height is 394 mm.

To calculate the Variance, take each difference, square it, and then average the result:

$$\begin{aligned} \text{Variance: } \sigma^2 &= \frac{206^2 + 76^2 + (-224)^2 + 36^2 + (-94)^2}{5} \\ &= \frac{42,436 + 5,776 + 50,176 + 1,296 + 8,836}{5} \\ &= \frac{108,520}{5} = 21,704 \end{aligned}$$

So, the Variance is **21,704**.

And the Standard Deviation is just the square root of Variance, so:

$$\begin{aligned} \text{Standard Deviation: } \sigma &= \sqrt{21,704} \\ &= 147.32 \\ &= 147 \end{aligned}$$

3. The test scores of 42 students are shown in the table below. Calculate the mean.

Score	$x_i$	$f_i$	$x_i \cdot f_i$
[10, 20)	15	1	15
[20, 30)	25	8	200
[30,40)	35	10	350
[40, 50)	45	9	405
[50, 60)	55	8	440
[60,70)	65	4	260
[70, 80)	75	2	150
<b>Total</b>		<b>42</b>	<b>1,820</b>

$$\bar{x} = \frac{1,820}{42} = 43.33$$

Exercise:

Find the Sample Variance and Standard Deviation for the following data:

1. 10    9        8        10        11        19        12        13
2. 20    23        25        19        20        21        23        25        18
3. 50    51        55        56        49        48        51        50        53
4. 100   111       101       99        98        96        115       103       102

Answers:

- 1) 11.71; 3.42    2) 6.53; 2.55    3) 7.28; 2.7    4) 46.42; 6.81

### PART -A

1. Define measurement.
2. Define instrument.
3. Define instrumentation system.
4. Define standard.
5. Classify standard.
6. What is the relationship between true value and error?
7. What is calibration?
8. How error is classified?
9. What technique is used for analysing the data having random error?

### **PART –B**

1. Draw the functional block diagram of instrumentation system.
2. Give an example for instrumentation system.
3. What is the difference between zero error and backlash error?
4. Differentiate primary and secondary standard.
5. What is the relationship between standard deviation and variance?

### **PART-C**

1. Draw the generalised functional block diagram of an instrumentation system and explain the function of each block.
2. Illustrate the instrumentation system for bourdon tube pressure gauge.
3. Draw and explain the pressure thermometer.
4. Explain the different types of standards.
5. Discuss in detail the different types of error.
6. Problems on statistical analysis of test data.

[www.binils.com](http://www.binils.com)

## UNIT – II PERFORMANCE CHARACTERISTICS OF INSTRUMENTS

### 2.1.Static characteristics

The performance criteria for the measurement of quantities that remain constant is called static characteristics.

#### Range

It can be defined as the measure of the instrument between the lowest and highest readings it can measure.

Eg: A thermometer has a scale from  $-40^{\circ}\text{C}$  to  $100^{\circ}\text{C}$ . Thus the range varies from  $-40^{\circ}\text{C}$  to  $100^{\circ}\text{C}$ .

#### Span

It can be defined as the algebraic difference between minimum and maximum scale value.

Eg: In the case of a thermometer, its scale goes from  $-40^{\circ}\text{C}$  to  $100^{\circ}\text{C}$ . Thus its span is  $140^{\circ}\text{C}$ .

#### Accuracy

The degree of closeness of measured value to the true value is called accuracy.

#### Precision

The degree of reproducibility with which repeated measurements of the same variable can be made under identical conditions is called precision.

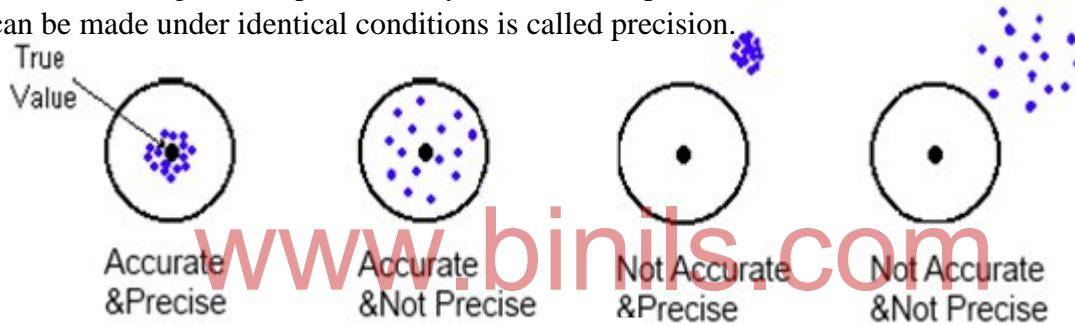

Fig.2.2

#### Significant figure

It conveys the actual information regarding the magnitude and measurement precision. The greater the significant figure the greater the precision.

All non zero digits are significant.	549 has three significant figures 1.892 has four significant figures
Zeros between non zero digits are significant.	4023 has four significant figures 50014 has five significant figures
Trailing zeros (the right most zeros) are significant when there is a decimal point in the number.	400. has three significant figures 2.00 has three significant figures 0.050 has two significant figures
Exact numbers have an infinite number of significant digits	If you count 2 pencils, then the number of pencils is 2.000...
Zeros to the left of the first non zero digit are not significant.	0.000034 has only two significant figures. (This is more easily seen if it is written as $3.4 \times 10^{-5}$ ) 0.001111 has four significant figures.
Trailing zeros are not significant in numbers without decimal points.	470,000 has two significant figures 400 or $4 \times 10^2$ indicates only one



significant figure. (To indicate that the trailing zeros are significant a decimal point must be added. 400. has three significant digits and is written as  $4.00 \times 10^2$  in scientific notation.)

**Range of doubt or possible error:**

It is defined as the largest deviation from arithmetic mean.

Example:

If  $A = 131 \pm 4$  and  $B = 106 \pm 4$ , the percentage range of doubt in  $A - B$  is

**Explanation:**

$(A - B) = 25 \pm 8$ . Therefore, % range of doubt .  $= \frac{8}{25} \times 100 = 32\%$

**Dead time**

Dead-time can be defined as the time taken by an instrument to begin its response for a change in measured quantity.

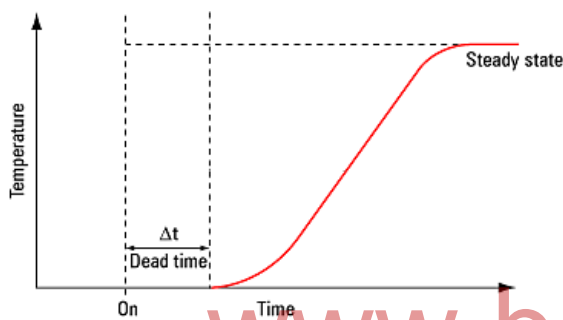

Fig.2.2

**Dead zone or dead band or dead space:**

The **dead-band** is defined as the largest change in the input quantity to which the measuring system does not repond. It is due to friction, backlash or hysteresis.

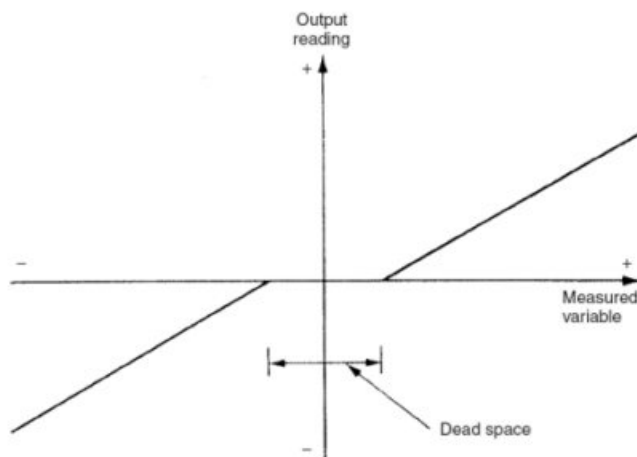

Fig.2.3

**Hysteresis :**

It is a phenomenon which shows different output effect when loading and unloading. It is due to friction or backlash error.

Ex: mechanical system or electrical system.

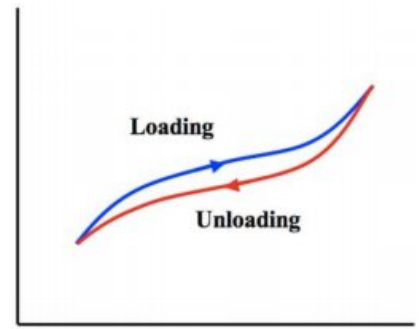

Fig.2.4

**Threshold**

Threshold is defined as a smallest measurable input.

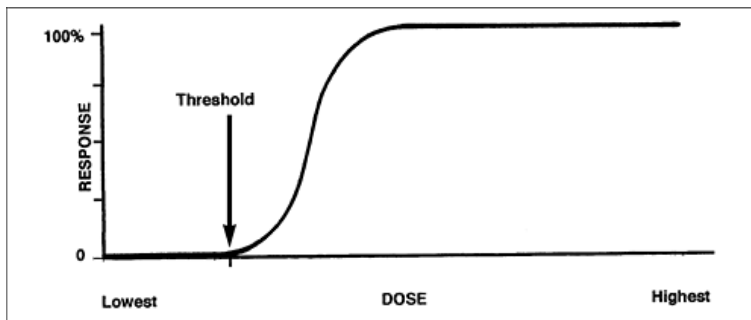

Fig.2.5

**Resolution :**

The smallest measurable input change needed to produce a change in the output signal is called resolution.

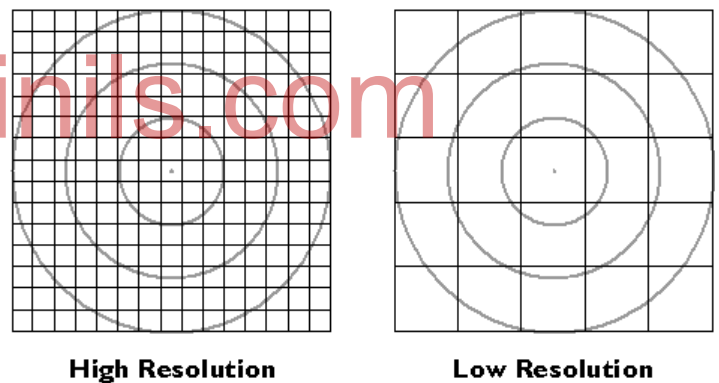

Fig.2.6

**Sensitivity:**

The sensitivity is defined as the ratio of the changes in the output of an instrument to a change in the input quantity. Mathematically it is expressed as,

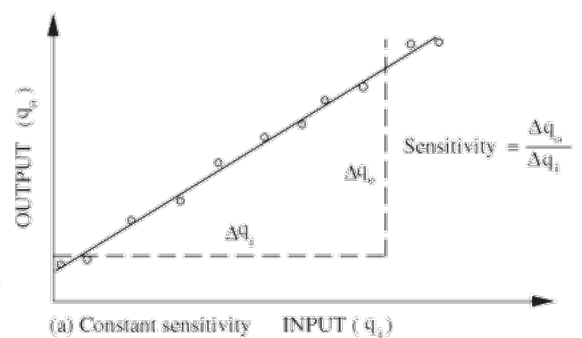

Fig.2.7

**Linearity:**

Linearity is defined as the proportionality between input quantity and output quantity. i.e as input increases output also increases or as input decreases output also decreases

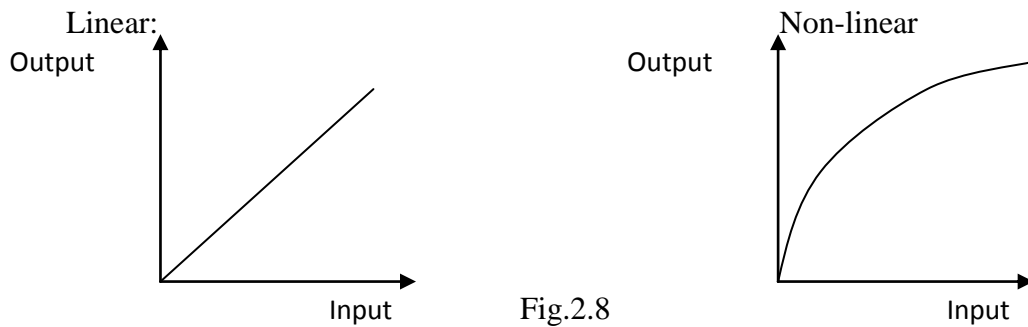

Fig.2.8

### Stability

The ability of a measuring instrument to retain its calibration over a long period of time.

### Reproducibility:

The degree of closeness with which a given value can be repeatedly measured under different conditions.

### Loading effect:

The incapability of the system to faithfully measure, record or control the input signal in undistorted form is called the loading effect.

To minimise the loading effect,

- Input impedances should be high so that the current it draws is minimum and not 'overloaded'.
- Output impedances should be low load because most of the signal's voltage will be 'lost' inside the circuit driving current if high.

### 2.2 Dynamic characteristics:

The set of criteria defined for the instruments, which changes rapidly with time, is called 'dynamic characteristics'.

The various dynamic characteristics are:

- i) Speed of response
- ii) Measuring lag
- iii) Fidelity
- iv) Dynamic error

#### **Speed of response:**

It is defined as the rapidity with which a measurement system responds to changes in the measured quantity.

#### **Measuring lag:**

It is the retardation or delay in the response of a measurement system to changes in the measured quantity.

#### **Fidelity:**

It is defined as the degree to which a measurement system indicates changes in the measure and quantity without dynamic error.

#### **Dynamic error:**

It is the difference between the true value of the quantity changing with time & the value indicated by the measurement system if no static error is assumed. It is also called measurement error.

### 2.3. Standard test input signal:

For the analysis point of view, the signals, which are most commonly used as reference inputs, are defined as **standard test inputs**. The performance of a system can be evaluated with respect to these test signals. Based on the information obtained the design of control system is carried out. The standard test signals are.

1. Impulse input signals
2. Step Input signals.
3. Ramp Input Signals.
4. Parabolic Input Signals.

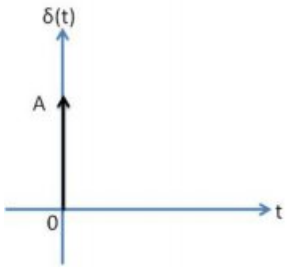
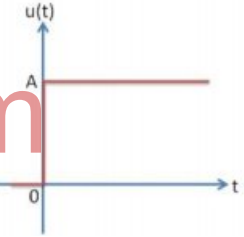
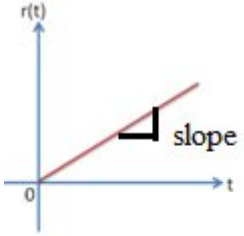
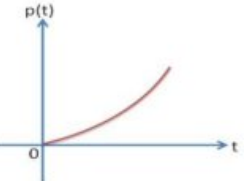
Signals -definition	Example	Equation	Graph
<p><u>Impulse signal:</u> The signal which has zero value everywhere except at <math>t=0</math> is called impulse signal.</p>	Sudden shock	$\delta(t) = \begin{cases} A & t = 0 \\ 0 & t \neq 0 \end{cases}$	
<p><u>Step signal:</u> The signal that represents an a sudden change is called step signal.</p>	Sudden opening or closing of a valve	$u(t) = \begin{cases} A & t \geq 0 \\ 0 & t < 0 \end{cases}$	
<p><u>Ramp signal:</u> The signal which changes at constant rate with respect to time is called ramp signal.</p>	Altitude control of a missile.	$r(t) = \begin{cases} At & t \geq 0 \\ 0 & t < 0 \end{cases}$ <p>where A is the slope.</p>	
<p><u>Parabolic signal:</u> The signal which is proportional to square of time is called parabolic signal</p>	Acceleration	$p(t) = \begin{cases} \frac{At^2}{2} & t \geq 0 \\ 0 & t < 0 \end{cases}$	

## 2.4 Dynamic response – Steady state and Transient response.

### Dynamic response:

The behaviour of the system when inputs vary with time and so the output also varies is called dynamic response.

$$c(t) = c_{tr}(t) + c_{ss}(t)$$

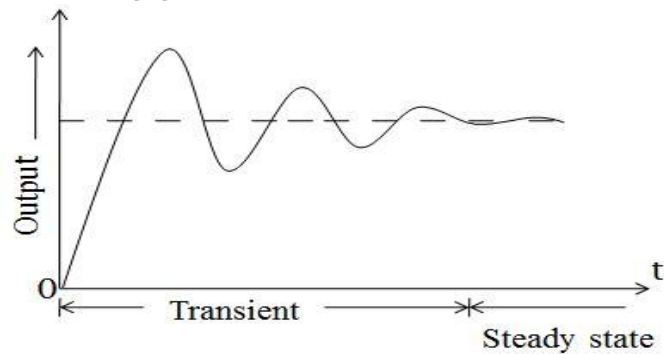

Fig.2.9

The dynamic response is divided into

### Transient response:

The part of dynamic response which goes to zero error as time becomes large is called transient response.

$$\lim_{t \rightarrow \infty} c_{tr}(t) = 0$$

### Steady state response:

The response when time reaches infinity.

$$\lim_{t \rightarrow \infty} c(t) = c_{ss}(t)$$

## **PART-A**

1. Define static characteristics.
2. Define dynamic characteristics.
3. What are the standard test input signals?
4. What is dynamic response?
5. List out the static characteristics.
6. Define range.
7. Define span.
8. Define accuracy.
9. Define precision.
10. Define threshold.
11. Define resolution.
12. Define stability.
13. Define reproducibility.
14. Define sensitivity.
15. List out the dynamic characteristics.

## **PART-B**

1. What is significant figure ?
2. Define dead time and dead zone.
3. Explain hysteresis.
4. Define linearity.
5. What is range of doubt ?

## **PART-C**

1. Explain loading effect.
2. Explain standard test input signal.
3. Explain dynamic response.
4. Explain static characteristics.
5. Explain dynamic characteristics.

## UNIT – III SENSORS AND TRANSDUCERS

### 3.1 Transducer

A **transducer** is defined as a device which converts energy from one form to another. A transducer includes devices which convert physical quantity into an electrical signal.

Physical quantity like heat, intensity of light, flow rate, liquid level, humidity, pH value, etc. may also be converted into electrical form like voltage, resistance etc by means of transducers.

### 3.2 Classification of Transducers

Transducers can be classified as

1. Primary and Secondary transducers
2. Passive and Active transducers
3. Analog and Digital transducers
4. Transducers and Inverse transducers

#### 1. Primary and Secondary Transducers

##### Primary Transducer:

The transducer which senses the measurement and converts them into another variables (like displacement, strain etc.) and whose output forms the input of another transducer is called as primary transducer.

Examples:

1. Bourdon tube: used in pressure measurement .
2. Strain gauge: used in force and strain measurements

##### Secondary Transducer

The transducer which converts the output of primary transducer into an electrical output called secondary transducer.

Examples:

LVDT: Used to measure Displacement, Force, Pressure measurement and Position

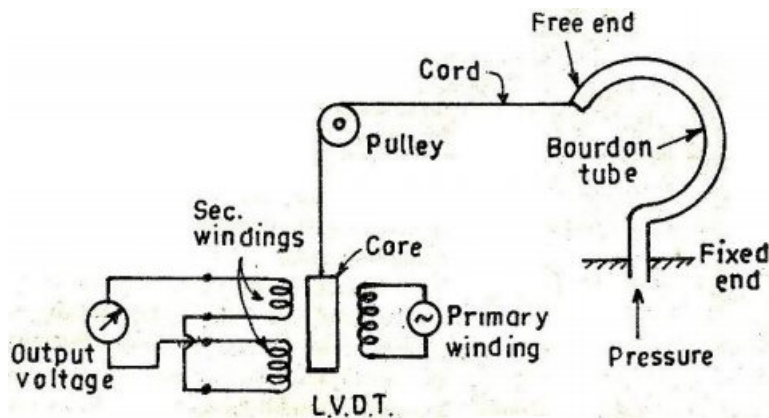

Fig.3.1

For eg. The Bourdon tube is primary transducer, converts the input pressure into a displacement. The LVDT is secondary transducer, converts this displacement into voltage.

#### 2. Passive and active Transducers:

##### Active Transducer:

The transducer which does not requires any external excitation to provide their outputs are referred as active transducer. Thus active transducers are self-generating devices.

Examples:

1. Photo voltaic cell: used in light meters and in solar cells.
2. Thermocouple :used to measure Temperature , Radiation and Heat flow.

**Passive Transducer:**

The transducer which requires an external excitation to provide their output is referred as passive transducer. They are also known as externally powered transducers.

Examples:

1. Capacitive transducers: used to measure liquid level, noise, thickness.
2. Resistive transducers. Used to measure temperature, pressure, displacement.
3. Inductive transducers: used to measure pressure, vibration, position, displacement .

**ACTIVE- Eg: PHOTOVOLTAIC CELLS**

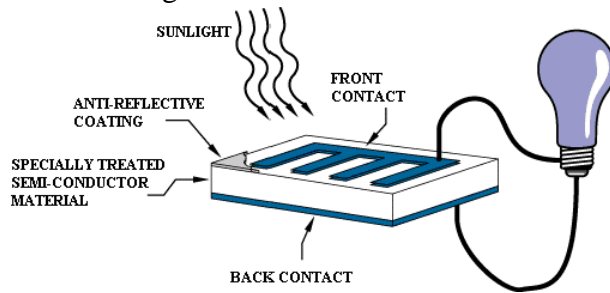
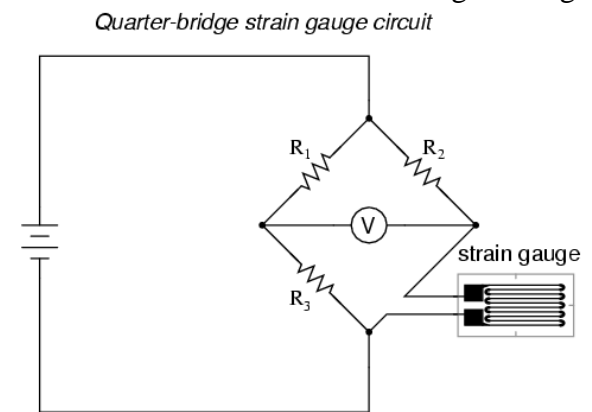

Fig.3.2

**PASSIVE- Resistive transducer-Eg Strain gauge**



**3. Analog and Digital Transducers**

**Analog Transducer:**

The transducer which produces their outputs in analog form or a form which is a continuous function of time is referred as analog transducer.

Example:

1. Strain gauge: used to measure, Displacement ,Force and torque measurement etc.
2. Thermistor: used to measure, Temperature and Flow measurement etc..

**Digital Transducer:**

The transducer which produces their outputs in digital form or a form of pulses is referred as digital transducers. Examples: optical encoder.

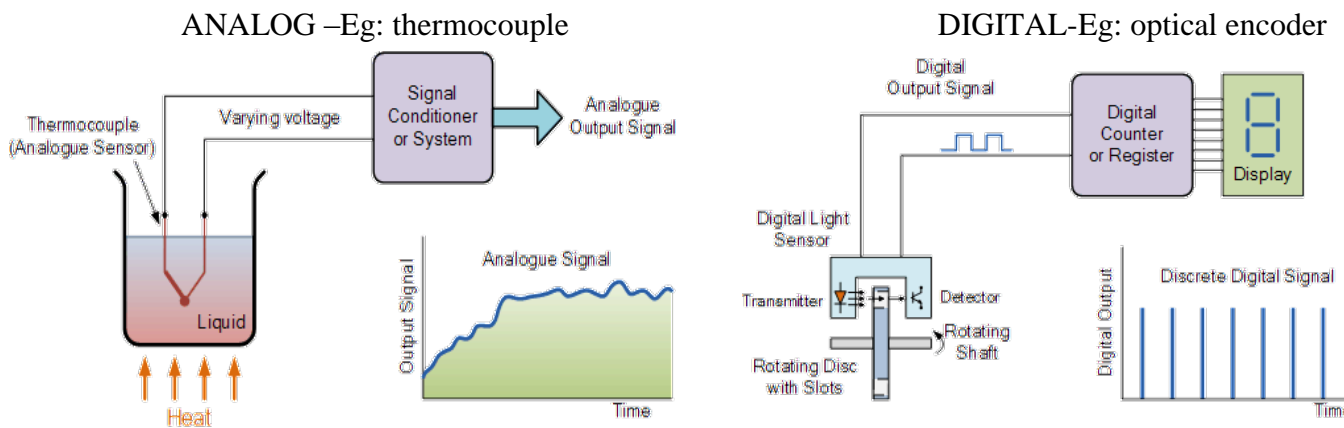

Fig.3.3



#### 4. Transducers and Inverse Transducers

A **transducer** is defined as a device which converts a non-electrical quantity into an electrical quantity. Example: thermistors

An **inverse transducer** is defined as a device which converts an electrical quantity into a non-electrical quantity.

Example: piezoelectric crystal acts as an inverse transducer because when a voltage is applied across its surfaces, it changes its dimensions causing a mechanical displacement that is conversion of electrical pulses to mechanical vibration. Eg: Piezoelectric crystal

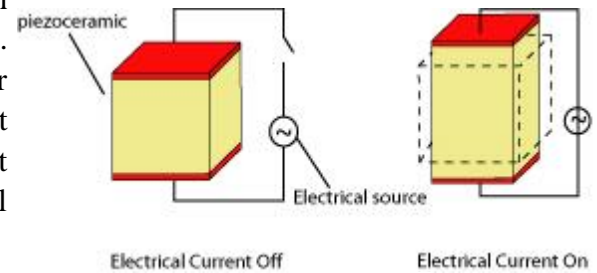

Fig.3.4

#### 3.3 Characteristics of transducer:-

##### Input characteristics:

Type of input and operating range:

1. Input quantity chosen must be measurable.
2. Type of input for any transducer depends on the range of input. Upper limit is the transducer capability. Lower limit is transducer error.
3. For total operating range, resolution must be good.

Loading effect:

Loading refers to the phenomena that occur when a load circuit having low effective impedance is connected to a supply circuit having higher effective impedance. This can be eliminated if the load resistance is much greater than the source resistance.

##### Transducer response:

Transducer Response depends on environmental influence ie not accurate due to environmental condition. So it should work under constant environmental condition. The disturbances may be electromagnetic and electrostatic fields, mechanical shocks and vibration, temperature change, pressure change and humidity change. It is protected by grounding or guarding against interfering & modifying input due to environmental effect.

##### Output characteristics:

Condition to be considered for output characteristics are,

- ❖ Type of electrical output.
- ❖ Output impedance.
- ❖ Useful range.

Type of electrical output:

1. Voltage, current, impedance (or) time function of this impedance may be the transducer output.
2. Transducer must be accepted by next stage for further processing like amplification, attenuation, filtering etc.

Output impedance of transducer  $(Z_o)_T$ :

To minimize the loading effect  $(Z_o)_T = 0$ . But practically  $(Z_o)_T$  is not zero but it should be as low as possible and also if  $(Z_o)_T = (Z_o)_{s.s}$  then maximum power is transferred & is matched with next stage.

Useful output range:

- It is limited by noise signals.
- Upper limit is set by maximum input.
- Range can be increased by amplifier but if amplifier increases noise level then it is of no use. so care must be taken.

### 3.4. Selection of transducer:

1. Operating principle.	8. Loading effects.
2. Sensitivity.	9. Environmental compability.
3. Operating range.	10. Insitirity of unwanted signal.
4. Accuracy	11. Usage&rugged
5. Cross sensitivity.	12. Electrical aspects.
6. Error.	13. Stability reliability.
7. Transient & frequency response.	14. Static characteristics.
	15. Size

1. **Operating Principle:** The transducer is many times selected on the basis of operating principle used by them. The operating principle used may be resistive, inductive, capacitive, optoelectronic, piezo electric etc.
2. **Sensitivity:** The transducer must be sensitive enough to produce detectable output.
3. **Operating Range:** The transducer should maintain the range requirement and have a good resolution over the entire range.
4. **Accuracy:** High accuracy is assured.
5. **Errors:** The transducer should maintain the expected input-output relationship as described by the transfer function so as to avoid errors.
7. **Transient and frequency response:** The transducer should meet the desired time domain specification like peak overshoot, rise time, setting time and small dynamic error.
8. **Loading Effects:** The transducer should have a high input impedance and low output impedance to avoid loading effects.
9. **Environmental Compatibility:** It should be assured that the transducer selected to work under specified environmental conditions maintains its input- output relationship and does not break down.
10. **Insensitivity to unwanted signals:** The transducer should be minimally sensitive to unwanted signals and highly sensitive to desired signals.
11. **Usage & ruggedness:** both mechanical & electrical transducers are used depending upon the size and weight while selecting a suitable transducer.
12. **Electrical aspects:** Transducer must be battery operator and must be properly shielded.
13. **Stability & reliability:** A transducer must be highly stable and highly reliable.
14. **Static characteristics:** The transducers must have low linearity , low hysteresis, and high resolution. The transducers selected should be free from temperature effects ,and load alignments effects
15. **Size:** A transducer must have small size, proper shape and minimum volume and also the operating range must be more.

### 3.5 Electrical Transducer:

A transducer which provides output as an electrical signal is known as electrical transducer .The electrical signal may be in the form of

- Voltage  
Eg. A microphone takes sound waves turns it into electrical energy.
- Current  
Eg. A thermocouple converts temperature into a current.
- Change in resistance,  
Eg. The strain gauge is converts the mechanical elongation and compression into a resistance change.

- Change in capacitance,  
Eg. The capacitive sensor can be used to control the frequency of a resonant circuit to convert the capacitive change into a useable electrical output.
- Change in inductance.  
Eg. LVDT, the displacement is converted into a change in inductance of a single coil.

### Advantages of electrical Transducer over Mechanical Transducer.

- Mass-inertia effects are minimized.
- Effects of friction are minimized.
- Electrical amplification and attenuation can be easily done.
- The output can be modified to meet the requirements of indicating or controlling units. The signal magnitude can be related in terms of the voltage and current.
- The output signal can be converted into digital form and can be stored for further reference.
- The output can be indicated or recorded remotely at a distance from the sensing medium.
- The output can be easily transmitted and processed for the purpose of measurement.
- The electrical system can be controlled with very small power level.

### 3.6 Sensor:

The main **difference between sensor and transducer** is that a **transducer** is a device that can convert energy from one form to another, whereas a **sensor** is a device that can detect a physical quantity and convert the data into an electrical signal. **Sensors** are also a type of **transducers**.

#### Pressure sensor:

A pressure sensor is a device that senses pressure and converts it into an electric signal where the amount depends upon the pressure applied.

Eg. Strain gage, variable capacitance, and piezoelectric.

Piezoelectric transducer:

- ❖ When pressure is applied to certain crystal, it will deform and produce a small voltage. This phenomenon is called the piezoelectric effect.
- ❖ Piezo electric crystals used are ammonium dihydrogen phosphate and sintered ceramics.
- ❖ When the piezoelectric effect is used in a pressure sensor, the sensor uses a diaphragm that deflects slightly when pressure is applied.
- ❖ A rod transfers this small amount of movement directly to the piezoelectric crystal.
- ❖ The pressure on the crystal causes a small voltage to be produced that is proportional to the pressure.
- ❖ The voltage is amplified to standard voltage signal values (0-10 volts).

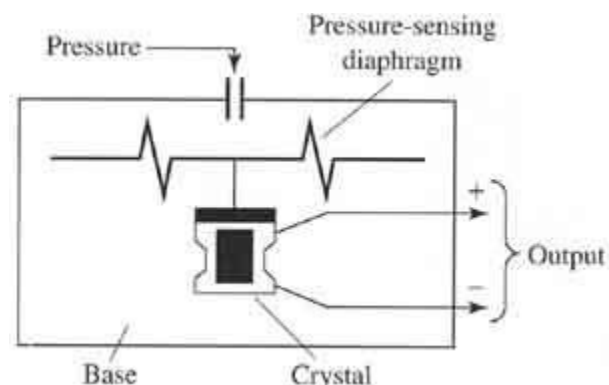

Fig.3.5

#### Biosensor:

- ❖ A biosensor is an analytical device which converts a biological response into an electrical signal.
- ❖ A biosensor consists of two components: a bioreceptor and a transducer.
- ❖ The bioreceptor is a biomolecule that recognizes the target analyte without using reagents. Examples: Enzymes, antibodies, nucleic acids

- ❖ The transducer converts the action of bioreceptor molecule into a measurable signal.
- ❖ The types of transducers used for converting the action of the bioreceptor molecule into measurable signal are:
  - Electrochemical transducer
  - Piezoelectric transducer
  - Optical transducer
  - Acoustic transducer
  - Thermal transducer
- ❖ The output of transducer is amplified, processed and displayed by user interface.

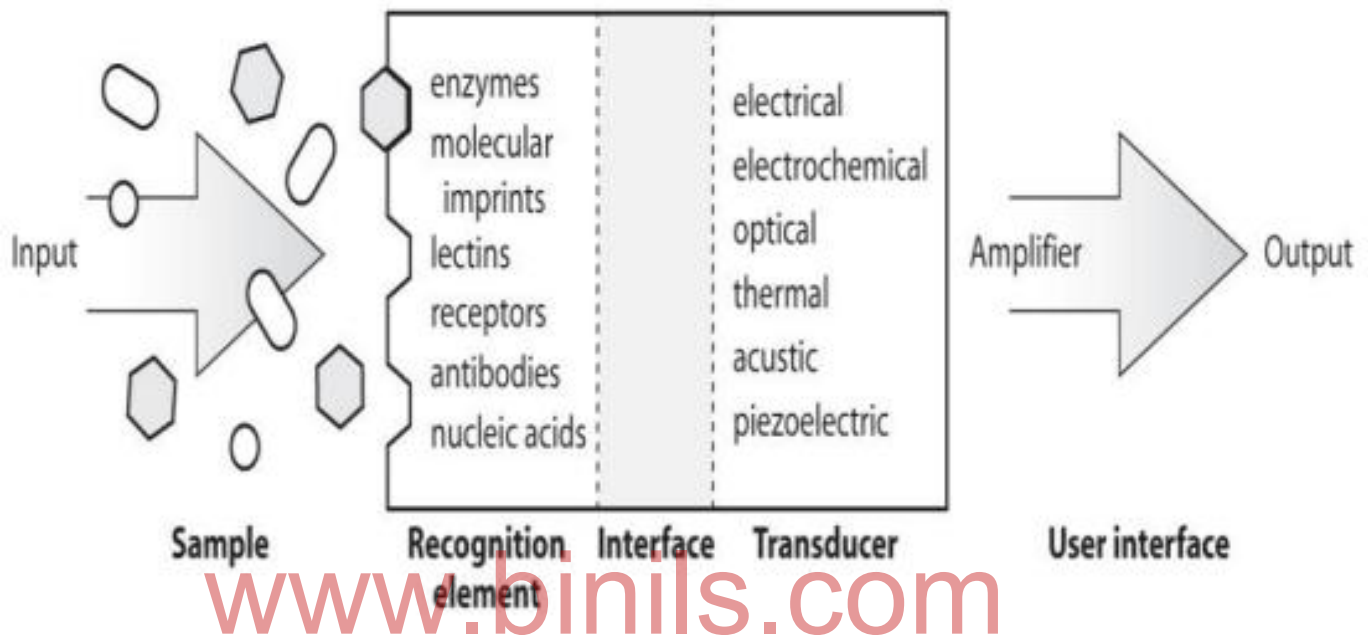

Fig.3.6

### Proximity sensor

A sensor which converts information on the movement or presence of an object into an electrical signal is called *proximity sensor*.

Types:

1. Inductive proximity sensors,
2. Capacitive proximity sensors,
3. Magnetic proximity sensors and
4. Photoelectric proximity sensor.

#### Inductive proximity sensors

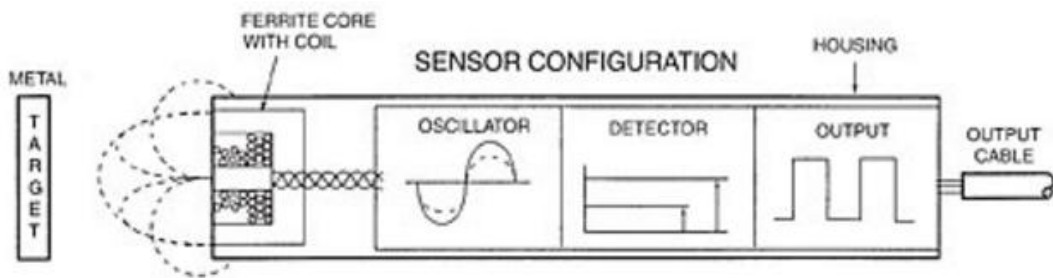

Fig.3.7

- ❖ An Inductive Proximity Sensor consists of a ferrite core with coil, an oscillator, a detector circuit, an output circuit, housing, and a cable or connector.
- ❖ The **oscillator** generates a sine wave of a fixed frequency. This signal is used to drive the coil.
- ❖ The **coil** in conjunction with **ferrite core** induces an electromagnetic field.
- ❖ When the field lines are interrupted by a metal object, the oscillator voltage is reduced, proportional to the size and distance of the object from the coil.
- ❖ The reduction in the oscillator voltage is caused by eddy currents induced in the metal interrupting the field lines. This reduction in voltage of the oscillator is detected by the **detecting circuit**.
- ❖ An **output** signal is generated when the oscillator voltage drops below a present level.

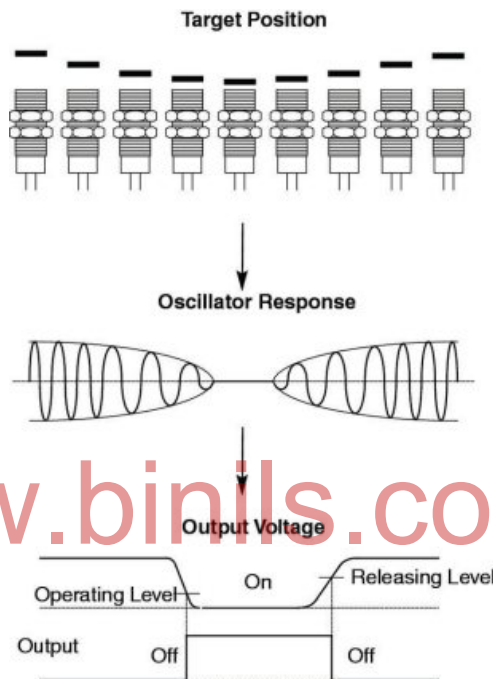

Fig.3.8

### Magnetic sensors

Magnetic sensors detect changes and disturbances in a magnetic field like flux, strength and direction.

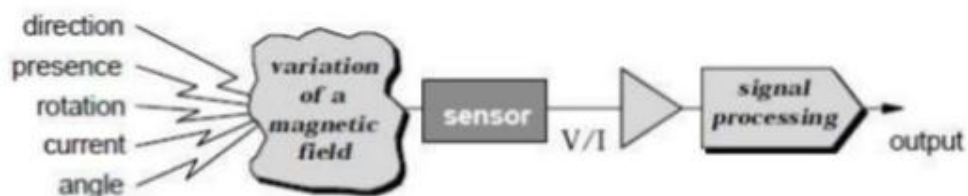

Fig.3.9

On the basis of sensing the variation of magnetic fields, magnetic sensors are classified into three types, 1) Low field sensors. 2) Earth field sensors. 3) BIAS Magnetic field sensors.

### Eg. Flux Gate magnetometer.

- The flux-gate magnetometer is an **Earth's Field (Medium-Field) Sensor**.
- It incorporates two coils, a primary and a secondary, wrapped around a common high-permeability ferromagnetic core.
- The core's magnetic induction changes in the presence of an external magnetic field.
- A drive signal  $V_{DRIVE}$  applied to the primary winding at frequency  $f$  causes the core to oscillate between saturation points. The core saturation is caused by the change in its magnetic flux.
- The secondary winding outputs a signal that is coupled through the core from the primary winding.
- This signal is affected by changes in the core's permeability and appears as an amplitude variation in the sensing coil's output.
- The difference is due to the external magnetic field.
- The signal can be demodulated with a phase-sensitive detector and low pass filter to retrieve the magnetic field value.

#### Application

- Compass-based navigation systems
- Military for submarine detection.
- Geophysical prospecting and airborne magnetic field mapping operations

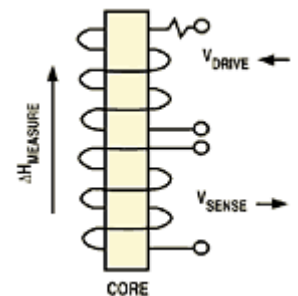

Fig.3.10

### Hall effect sensor.

A device which converts magnetic information into electrical signal is called **hall effect sensor**.

When an electric current is passed through the semiconductor while a magnetic field **B** is applied perpendicular to both the surface, a Hall voltage is produced perpendicular to the direction of current flow. This effect is called Hall Effect.

- ❖ A **Hall Effect Sensor** consists of a thin piece of rectangular p-type semiconductor material.

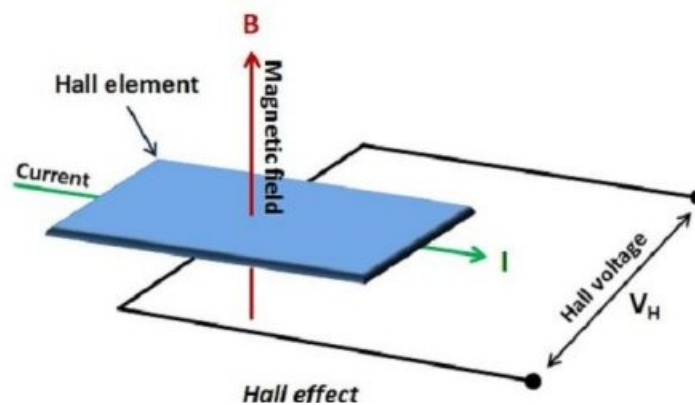

Fig.3.11

- ❖ The semiconductors used in Hall Effect devices are **Gallium arsenide (GaAs), indium antimonide (InSb), indium arsenide (InAs), Silicon (Si)**.
- ❖ When the device is placed in a magnetic field, the magnetic flux lines exert a force on the semiconductor material.
- ❖ As the electrons and holes move, a potential difference is produced.
- ❖ The effect of generating a measurable voltage by using a magnetic field is called the **Hall Effect**.

- ❖ To generate a potential difference across the device the magnetic flux lines must be perpendicular, (90°) to the flow of current.

❖ Thus

$$V_H = R_H \left( \frac{I}{t} \times B \right)$$

- Where:
- $V_H$  is the Hall Voltage in volts
- $R_H$  is the Hall Effect co-efficient
- $I$  is the current flow through the sensor in amps
- $t$  is the thickness of the sensor in mm
- $B$  is the Magnetic Flux density in Teslas

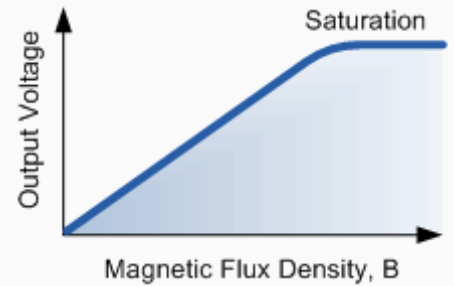

Fig.3.12

- ❖ Hall Effect sensors are used for positioning, speed detection, and current sensing applications.

### Displacement Sensors

- ❖ These sensors can be used to measure distances and heights.
- ❖ The LVDT (Linear Variable Differential Transformer) is a displacement measuring instrument.
- ❖ LVDT works under the principle of mutual induction in which the displacement which is a non-electrical energy is converted into an electrical energy.

### Construction

- ❖ The device consists of a primary winding (P) and two secondary windings S1 and S2.
- ❖ Both of them are wound on one cylindrical former, side by side, and they have equal number of turns.
- ❖ Their arrangement is such that they maintain symmetry with either side of the primary winding (P).
- ❖ A movable soft iron core is placed parallel to the axis of the cylindrical former.
- ❖ An arm is connected to the other end of the soft iron core and it moves according to the displacement produced

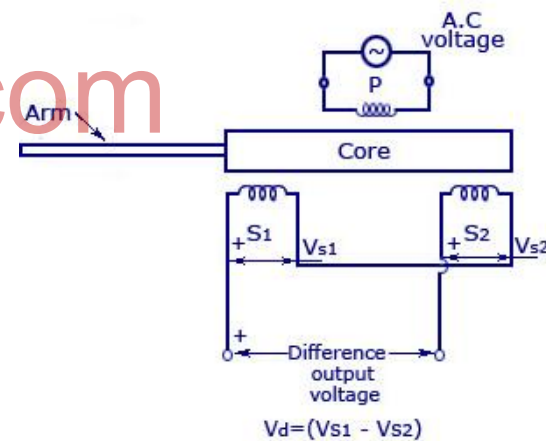

Fig.3.13

### Working

- ❖ An ac voltage of frequency between (50-400) Hz is supplied to the primary winding.
- ❖ Thus, two voltages  $V_{S1}$  and  $V_{S2}$  are induced at the two secondary windings S1 and S2 respectively.
- ❖ The output voltage will be the difference between the two voltages ( $V_{S1}-V_{S2}$ ) as they are connected in series.

**Case 1 -Null Position** –The core is at null position if there is no displacement. Thus the linking magnetic flux produced in the two secondary windings will be equal. The voltage induced because of them will also be equal. Thus the resulting voltage  $V_d = V_{S1}-V_{S2} = 0$ .

**Case 2-Right of Null Position** – In this position, the linking flux at the winding S2 has a value more than the linking flux at the winding S1. Thus, the resulting voltage  $V_d = V_{S1}-V_{S2}$  is negative and  $V_{S1}$  will be 180 degrees out of phase with  $V_{S2}$ .

**Case 3-Left of Null Position** – In this position, the linking flux at the winding S2 has a value less than the linking flux at the winding S1. Thus, the resulting voltage  $V_d = VS1- VS2$  is positive and VS1 will be in phase with VS2.

Thus the magnitude and displacement can be easily calculated or plotted by calculating the magnitude and phase of the resulting voltage.

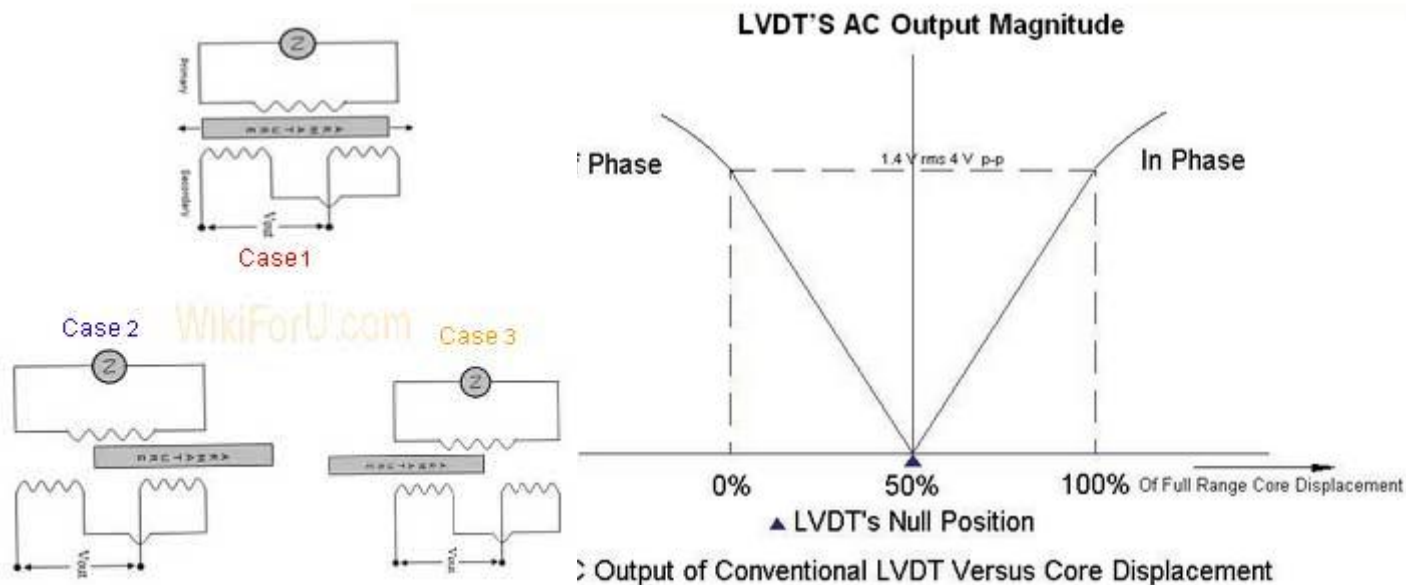

Fig.3.14

**Optical sensor:**

- An optical sensor converts light rays into electronic signals.
- It measures the physical quantity of light and then translates it into a form that is readable by an instrument.
- An optical sensor works with a source of light and a measuring device.
- It measures the changes from one or several light beams.
- When a change occurs, the light sensor operates as a photoelectric trigger and therefore either increases or decreases the electrical output.

**Types:**

Photoconductive devices or photoresistor (or light-dependent resistor, LDR, or photocell), Photovoltaics, Photodiodes, Phototransistors .

**Photoresistor**

1. It is a light-controlled variable resistor.
2. The resistance of a photoresistor decreases with increasing incident light intensity.
3. It exhibits photoconductivity.
4. A photoresistor is made of a high resistance semiconductor layer that is deposited on an insulating substrate.
5. In the dark, a photoresistor can have a resistance as high as several megohms (MΩ).
6. In the light, a photoresistor can have a resistance as low as few hundred ohms.
7. When light is incident on a photoresistor, photons absorbed by the semiconductor release electrons.



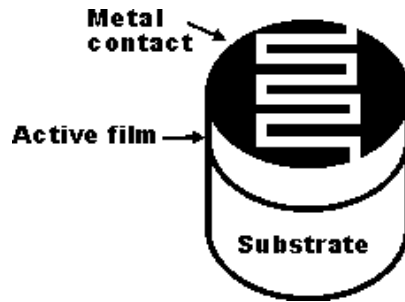

Fig.3.15

8. The resulting free electrons conduct electricity, so resistance decreases.
9. Materials used are lead sulfide, lead selenide, indium antimonide, and most commonly cadmium sulfide and cadmium selenide.

### PART –A

1. Define transducer?
2. Define inverse transducer?
3. Give an example for primary transducer.
4. Give an example for secondary transducer.
5. Differentiate active and passive transducer.
6. Identify the types of transducer:
  - A) Strain gauge:
  - B) Piezoelectric transducer:

### PART –B

1. How do the transducers are classified?
2. Define primary and secondary transducer. Give an example:
3. What are Active and Passive transducer?
4. Define Analog and Digital transducer?
5. Define electrical transducer. Give an example:
6. Define pressure sensor.
7. Define Bio sensor.
8. Define Proximity sensor.
9. Define Magnetic sensor.
10. Define Hall Effect sensor.
11. What are the materials used for Hall effect devices?
12. Write the equation for Hall voltage.
13. Give any two examples for displacement sensor.
14. Give any two examples for optical sensor.
15. Give the input and output of the following sensors.
  - A) Pressure sensor:
  - B) Bio sensor:
  - C) Proximity sensor:
  - D) Magnetic sensor:
  - E) Hall Effect sensor:
  - F) Displacement sensor:
  - G) Optical sensor:

### **PART –C**

1. Write about any two classification of transducer?
2. Explain the characteristics of transducer?
3. Discuss the various factors for selecting transducer.
4. Explain the working of a pressure sensor with neat diagram.
5. Explain the principle of working of a Proximity sensor.
6. Discuss the working of a displacement sensor with neat diagram.
7. Explain the working of a magnetic sensor.
8. Describe the working of Bio sensor.
9. What is Hall Effect? Explain the working of hall effect sensor with neat diagram.
10. Explain the Optical sensor with neat sketch.

[www.binils.com](http://www.binils.com)

## UNIT- IV - MECHANICAL TRANSDUCER

### Mechanical pressure transducer:

The mechanical pressure transducers are the mechanical elements that are used for converting pressure into other form that can be measured easily.

#### 4.1 Elastic sensors

- ❖ Most of the fluid pressure sensors are of the elastic type, where the fluid is enclosed in a small compartment with at least one elastic wall.
- ❖ The pressure reading is thereby determined by measuring the deflection of this elastic wall.
- ❖ This results in either a direct readout through suitable linkages, or a transduced electrical signal.
- ❖ The elastic sensors are Bourdon tube, bellows and diaphragms.

### Bourdon tube

#### Principle:

An increase in pressure on the inside of the tube in comparison to the outside pressure causes the oval or flat shaped cross-section of the tube to form a circular shape. This phenomenon causes the tube to either straighten itself out in the c-type or spiral cases or to unwind itself for the twisted and helical varieties. This change can then be measured with an analog or digital meter connected to the tube.

#### Construction and working:

- As pressure is applied internally, the tube straightens and returns to its original form when the pressure is released.
- The tip of the tube moves with the internal pressure change and is easily converted with a pointer onto a scale.
- A connector link is used to transfer the tip movement to the geared movement sector.
- The pointer is rotated through a toothed pinion by the geared sector.

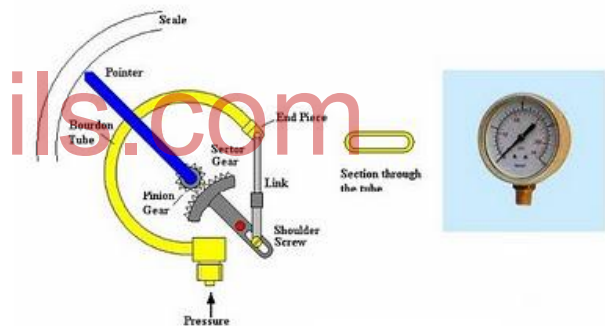

Fig.4.1

#### Types of bourdon tubes:

1. Straight tube
2. C-type
3. Twisted type
4. Helical type
5. Spiral type (a more coiled C-type tube),

#### Advantages

- Tube materials can be changed accordingly to suit the required process conditions.
- Bourdon tubes can operate under a pressure range from 0.1-700 MPa.
- They are also portable and require little maintenance.
- Bourdon tube gauges are the most popular in any process plant.

## Disadvantages

- They can only be used for static measurements and have low accuracy.
- This can be used for positive or negative pressure ranges, less accurate when vacuum.

## Applications

They are used to measure medium to very high pressure in highly automated chemical process such as refineries and petrochemical processing.

## Diaphragm:

### Principle of working:

- Diaphragms work on the principle of elasticity.
- It consists of a tough, pliable, neoprene rubber membrane connected to a metal spring that is attached by a simple linkage system to the gauge pointer.
- One side of the diaphragm is exposed to the pressure being measured, while the other side is exposed to the atmosphere.
- When pressure is applied to the diaphragm, it moves and through a linkage system, moves the pointer to a higher reading on the dial.
  - When the pressure is lowered, the diaphragm moves the pointer back toward the zero point.

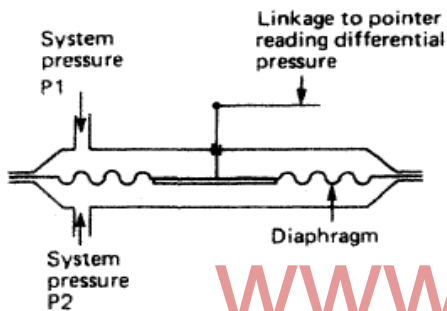

Fig.4.2

Diaphragm elements are made of circular metal discs or flexible elements such as rubber, plastic or leather. The metal type can measure a maximum pressure of approximately 7 MPa, The elastic type is used for measuring extremely low pressures (.1 kPa - 2.2 MPa).

### Types of diaphragms

flat, corrugated and capsule diaphragms.

### Uses

Diaphragm gauges are generally used to measure air pressure in the space between the inner and the outer boiler casings

## Bellows

### Principle

Bellows work on the principle of elasticity. Bellows deform in the axial direction (compression or expansion) with changes in pressure. The pressure that needs to be measured is applied to one side of the bellows (either inside or outside) while atmospheric pressure is on the opposite side.

### Construction and working:

- A bellow is made of several capsules .
- Bellow elements are cylindrical in shape and contain many folds called capsules.
- The capsule consists of two circular shaped, convoluted membranes (usually stainless steel) sealed tight around the circumference. The elastic elements in bellows gauges are made of brass, phosphor bronze, stainless steel, beryllium-copper.
- The membrane is attached at one end to the source and at the other end to an indicating device or instrument.
- One pressure is applied inside to the bellows, and the other pressure is applied to the outside.

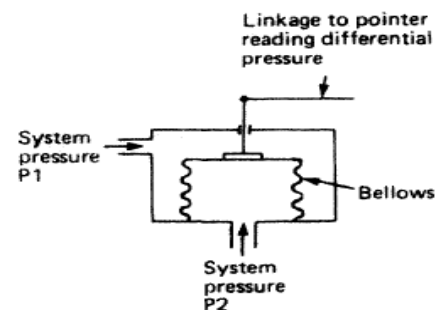

Fig.4.3

- A differential pressure reading is obtained and indicated.

#### Uses

Used in metallurgical iron smelting and welding for generating high amount of heat.

#### 4.2 Manometers:

Manometers measure a pressure difference by balancing the weight of a fluid column between the two pressures of interest. Large pressure differences are measured with heavy fluids, such as mercury. Small pressure differences are measured by lighter fluids such as water.

#### Types of manometer:

1. U Tube manometer
2. Well type manometer
3. Barometer
4. Inclined tube Manometer
5. Ring balance manometer
6. Micro manometer

#### U tube manometer:

U Tube manometer consists of a U-shaped glass tube partially filled with liquid.

With both legs of a U-tube manometer open to the atmosphere or subjected to the same pressure, the liquid maintains the same level in each leg, establishing a zero reference.

With a greater pressure applied to the left side of a U-tube manometer, the liquid lowers in the left leg and rises in the right leg. The liquid moves until the unit weight of the liquid, as indicated by  $h$ , exactly balances the pressure.

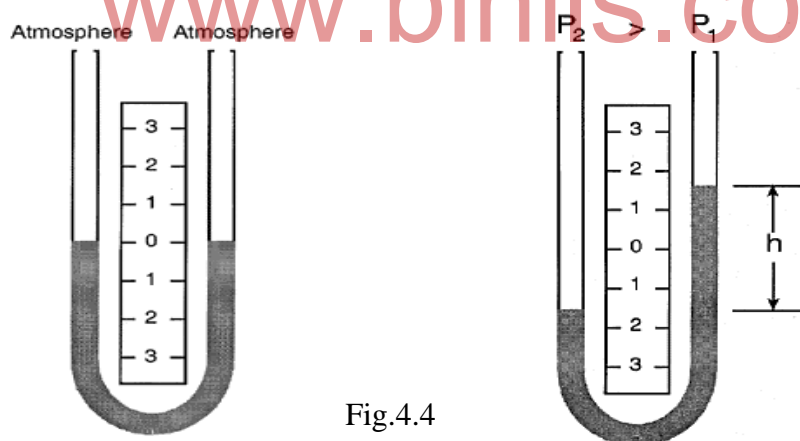

Fig.4.4

The fundamental relationship for pressure expressed by a liquid column is:

$$\Delta p = P_2 - P_1 = \rho gh \quad (1)$$

where:

$\Delta p$  = differential pressure

$P_1$  = pressure at the low-pressure connection,

$P_2$  = pressure at the high-pressure connection

$\rho$  = density of the indicating fluid (at a specific temperature)

$g$  = acceleration of gravity (at a specific latitude and elevation)

$h$  = difference in column heights

The resulting pressure is the difference between forces exerted per unit surface area of the liquid columns, with pounds per square inch (psi) or newtons per square meter (pascals) as the units.

### Well type manometer:

Variation in tube sizes is the well-type (or reservoir) manometer.

It consists of a single vertical tube and an relatively large reservoir called well as second column. The cross-sectional area of one leg (the well) is much larger than the other leg. Due to this the liquid motion inside is negligible in well.

When pressure is applied to the well, the fluid lowers slightly but the fluid rise is more in the other leg. So the height of single column is only measured for the pressure applied.

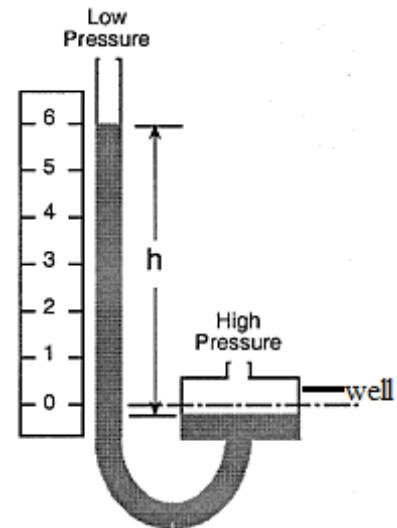

Fig.4.5

### Inclined tube manometers:

This manometer is arranged with the indicating tube inclined at an angle. So this provides an expanded scale. It is set at an angle  $\theta$  to the horizontal plane.

Then a pressure difference corresponds to a vertical difference of levels  $x$  gives a movement of the meniscus  $s = x/\sin(\theta)$  along the slope.

### Applications:

Accurate measurement of low pressure such as drafts and very low differentials, primarily in air and gas installations.

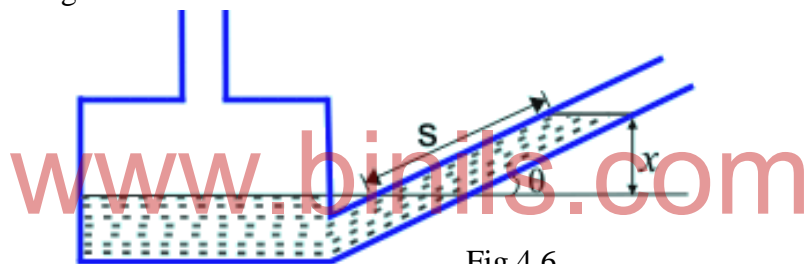

Fig.4.6

### Barometer:

#### Principle:

A barometer measures atmospheric pressure (also known as air pressure or barometric pressure)

The atmospheric pressure is the weight of air in the atmosphere.

The barometer works by balancing the weight of mercury in the glass tube against the atmospheric pressure above the reservoir.

#### Construction :

The barometer is typically a glass tube about 3 feet height with one end open and the other end sealed.

The tube is filled with mercury.

This glass tube sits upside down in a container, called the reservoir which also contains mercury.

The mercury level in the glass tube falls, creating a vacuum at the top.

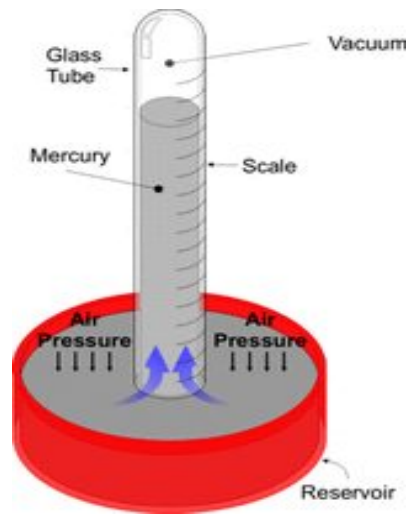

Fig.4.7

**Working:**

The level of mercury continues to change until the weight of mercury in the glass tube is exactly equal to the weight of air above the reservoir.

In areas of **low pressure**, the weight of air above the reservoir is low. The weight of mercury is more than the atmospheric pressure, so the **mercury level falls**.

In areas of **high pressure**, the weight of air is higher. The weight of mercury is less than the atmospheric pressure, so the **mercury level in the glass tube rises**.

The rise and fall of this mercury level is measured using scale.

**Ring balance manometer:**

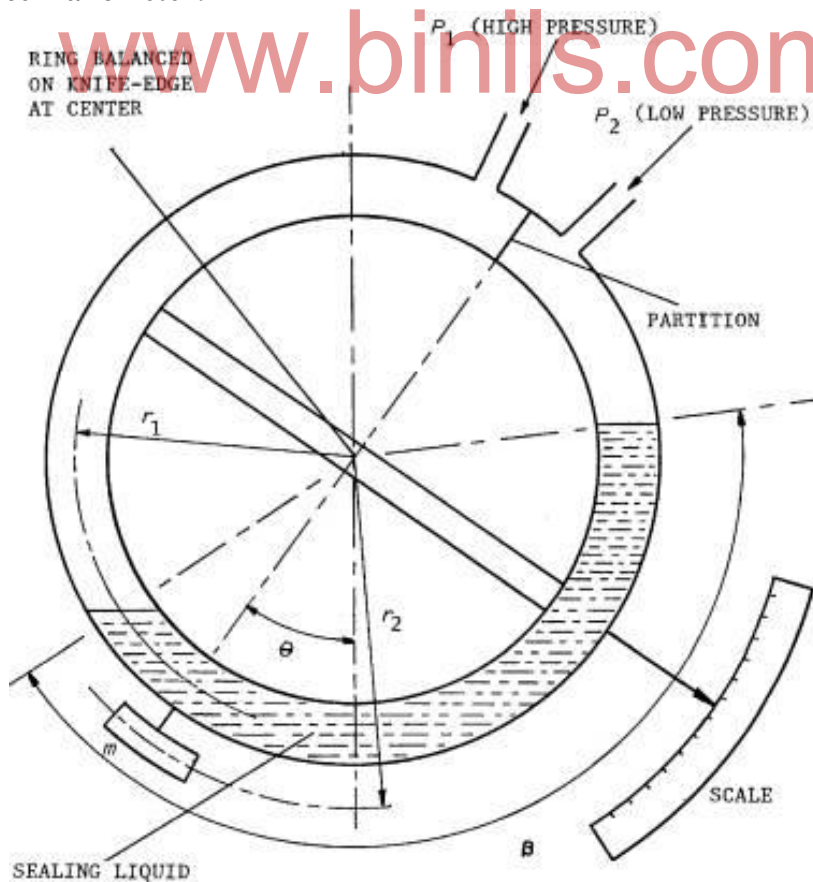

Fig.4.8

### Construction and working:

- The U-tube is formed into a ring, partitioned at the top and having a flexible connection at each side of the seal.
- The tube is partially filled with a sealing liquid of known specific weight.
- However, the tube is pivoted at its center so it is free to rotate through a vertical plane.
- A weight of known mass is attached to the tube at a point opposite to the partition.
- When a pressure difference is applied across the tube, the sealing liquid will be displaced away from the source of highest pressure.
- However the mass of the displaced liquid will also produce a turning moment causing the tube to rotate about its pivot.
- This in turn moves the weight off the vertical line of the pivot to produce an opposing turning moment, until a point is reached where both moments balance.
- The pressure applied then becomes a function of the degree of rotation and can be read directly from an appropriate scale.

$$p_1 - p_2 = \frac{mgr_2}{Ar_1} \sin\theta$$

$p_1$  represents the high pressure,  $p_2$  the low pressure,  $A$  the cross-sectional area of the tube,  $r_1$  the mean radius of the ring,  $m$  the mass attached to the bottom of the ring,  $r_2$  the radius of the point of application of the mass,  $\theta$  is the angle of rotation, and  $g$  is the acceleration constant of gravity.

### Micromanometer:

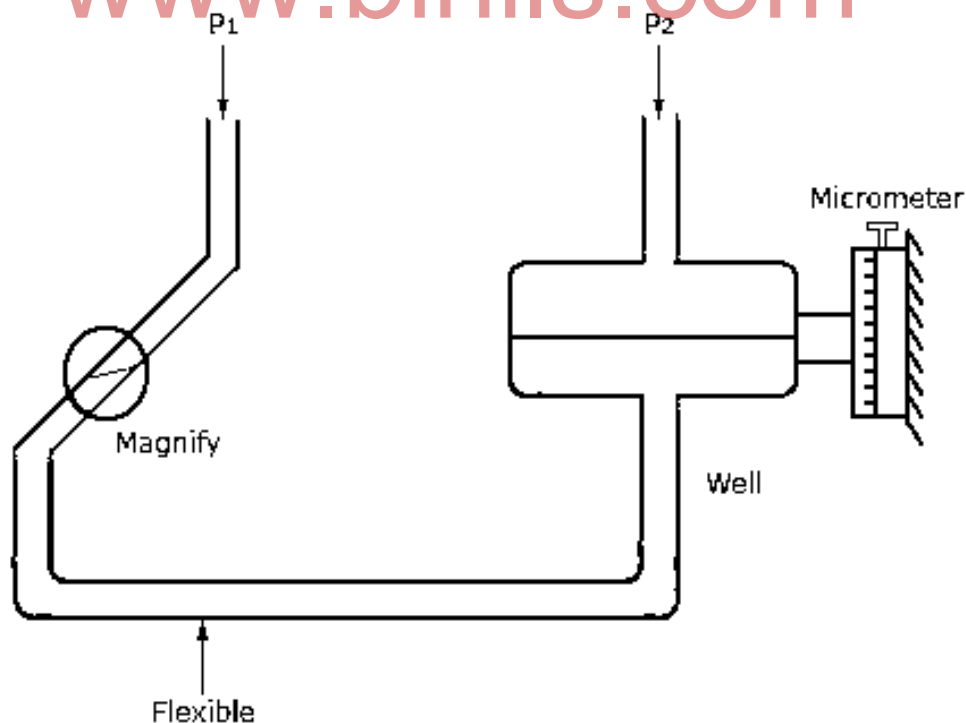

**Micromanometer** Fig.4.9

1. Micromanometer is based on the principle of inclined tube manometer.
2. It is used for the measurement of extremely small differences of pressure.



- For the condition,  $P_1 = P_2$ ,  
The meniscus of the inclined tube is at a reference level and is viewed through a magnifier provided with cross hair line.
- The adjustment is done by moving the well up and down using micrometer. The reading  $r_1$  is noted from micrometer scale.
- For the condition,  $P_1 \neq P_2$ ,  
The position of the meniscus is changed and is restored to reference level by rising or lowering the well using micrometer and the reading  $r_2$  is noted.
- The difference between these two readings  $r_1 - r_2$  gives the pressure difference in terms of height.

### Manometric fluids or indicating fluids:

Light liquids such as water can be used to measure small pressure differences; mercury or other heavy liquids are used for measuring large pressure differences. Indicating fluids can be coloured water, oil, bromides, pure mercury, Benzene Carbon tetrachloride, Ethyl alcohol, Kerosene and Toluene.

The following specifications also must be taken care.

- Must not be immiscible with other fluids.
- Must be easily seen.
- Should not be volatile.
- Should be denser than tested fluid.

### Thermal Detector:

#### Liquid in glass thermometer:

A liquid-in-glass thermometer uses the expansion of a liquid with increase in temperature.

#### Construction:

A typical liquid-in-glass thermometer consists of a sealed stem of uniform small-bore tubing called a capillary tube made of glass with a cylindrical glass bulb formed at one end.

The bulb and part of the stem are filled with a liquid such as mercury or alcohol and the remaining part of the tube is evacuated.

A temperature scale is formed by etching graduations on the stem.

A safety reservoir is usually provided, into which the liquid can expand without bursting the glass if the temperature is raised beyond the upper limit of the scale.

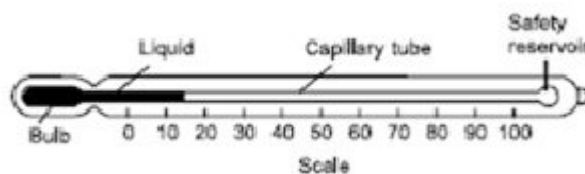

#### Working:

Fig.4.10

When the temperature increases, the liquid expands and then rises in the capillary tube in the thermometer.

The temperature can be noted by the level of liquid with the help of a scale etched on the outer side of the glass.

#### Application:

Used as clinical thermometer to measure body temperature.

Working liquid,

Mercury  $-35$  to  $65^\circ\text{C}$ ,

Alcohol  $-80$  to  $70^\circ\text{C}$ ,

Pentane  $-200$  to  $30^{\circ}\text{C}$ .

### Filled system thermometer:

The filled thermal device consists of

1. a primary element -a reservoir or bulb
2. a flexible capillary tube,
3. a hollow Bourdon tube that actuates a signal-transmitting device
4. a local indicating temperature dial.

In this system, the filling fluid expands as temperature increases. This causes the Bourdon tube to uncoil and indicate the temperature on a calibrated dial. The filling or transmitting medium is vapour, a gas, mercury, or another liquid.

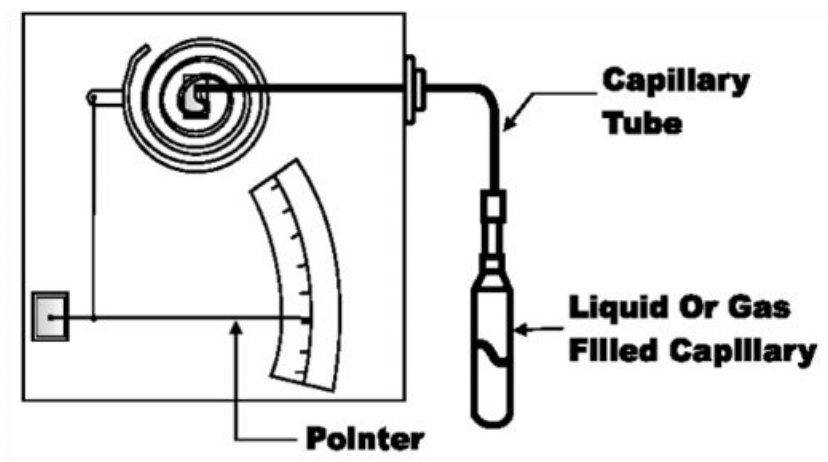

Fig.4.11

### Bimetallic thermometer:

#### Bi-metallic strip:

#### Principle:

Different metals have different coefficients of thermal expansion. So if they are heated they expand by different amounts.

#### Construction and working:

1. Two different metals, metal A with low coefficients -responds slower to change in temperature and metal B with larger coefficients – responds faster to change in temperature.
2. They are fixed together side by side.
3. One end is fixed and other end is free to move.
4. Before heating, the bimetallic strip is straight as shown in figure (a).
5. When heated ( temperature increases) metal B expands faster and bends upward as shown in figure(c ).
6. When cooled (temperature decreases) metal B contracts faster and bends downward as shown in figure (b)
7. Material used are: Metal A is steel and Metal B is copper or brass.

#### Applications:

Used in Thermostat in Air Conditioner, iron box, water heater, oven to regulate temperature.



Fig.4.12

Flow meters:

### Principle of orificemeter and venturimeter:

The working is based on the principle of Bernoulli's equation.

**Bernoulli's Statement:** it states that in a steady, ideal flow of an incompressible fluid, the total energy at any point of the fluid is constant. The total energy consists of pressure energy, kinetic energy and potential energy or datum energy.

*Pressure energy + Kinetic energy + Potential energy = Constant*

$$\frac{p}{\rho g} + \frac{v^2}{2g} + z = \text{Constant}$$

Mathematically

Here all the energies are taken per unit weight of the fluid.

The Bernoulli's equation for the fluid passing through the section 1 and 2 are given by

$$\frac{p_1}{\rho g} + \frac{v_1^2}{2g} + z_1 = \frac{p_2}{\rho g} + \frac{v_2^2}{2g} + z_2$$

**Orificemeter:**

**Construction:**

An orifice plate is a thin plate with a hole in it, which is usually placed in a pipe.

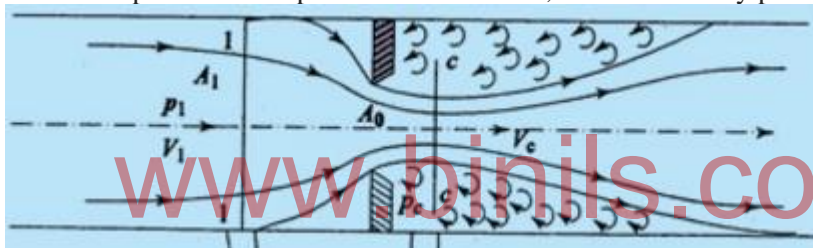

Fig.4.13

**Working:**

- When a fluid (whether liquid or gaseous) passes through the orifice, its pressure builds up slightly upstream of the orifice.
- As the fluid is forced to converge to pass through the hole, the velocity increases and the fluid pressure decreases.
- At the downstream of the orifice the flow reaches its point of maximum convergence, the *vena contracta* where the velocity reaches its maximum and the pressure reaches its minimum.
- Beyond vena contracta, the flow expands, the velocity falls and the pressure increases.
- By measuring the difference in fluid pressure using manometers across tappings upstream and downstream of the plate, the flow rate can be obtained from Bernoulli's equation using coefficients

$$Q_a = (C_d \cdot A_2 / \sqrt{1 - (A_2 / A_1)^2}) * (\sqrt{2(P_1 - P_2) / \rho})$$

Where,

Qa = flow rate

Cd = Discharge coefficient

A1 = Cross sectional area of pipe

A2 = Cross sectional area of orifice

P1, P2 = Static Pressures

**Venturimeter:**

A venturimeter is a device used for measuring the rate of flow of a fluid flowing through a pipe.

**Construction:**

The main parts of a venturimeter are:

- **A short converging part:** It is that portion of the venturi where the fluid gets converges.
- **Throat:** It is the portion that lies in between the converging and diverging part of the venturi. The cross section of the throat is much less than the cross section of the converging and diverging parts. As the fluid enters in the throat, its velocity increases and pressure decreases.
- **Diverging part:** It is the portion of the venturimeter (venturi) where the fluid gets diverges.

### Working

- The venturimeter is used to measure the rate of flow of a fluid flowing through the pipes.
- Considered two cross section, first at the inlet and the second one is at the throat.
- The difference in the pressure heads of these two sections is used to calculate the rate of flow through venturimeter.
- As the water enters at the inlet section i.e. in the converging part it converges and reaches to the throat.
- The throat has the uniform cross section area and least cross section area in the venturimeter. As the water enters in the throat its velocity gets increases and due to increase in the velocity the pressure drops to the minimum.
- Now there is a pressure difference of the fluid at the two sections. At the section 1 (i.e. at the inlet) the pressure of the fluid is maximum and the velocity is minimum. And at the section 2 (at the throat) the velocity of the fluid is maximum and the pressure is minimum.
- The pressure difference at the two sections can be seen in the manometer attached at both the section.
- This pressure difference is used to calculate the rate flow of a fluid flowing through a pipe.

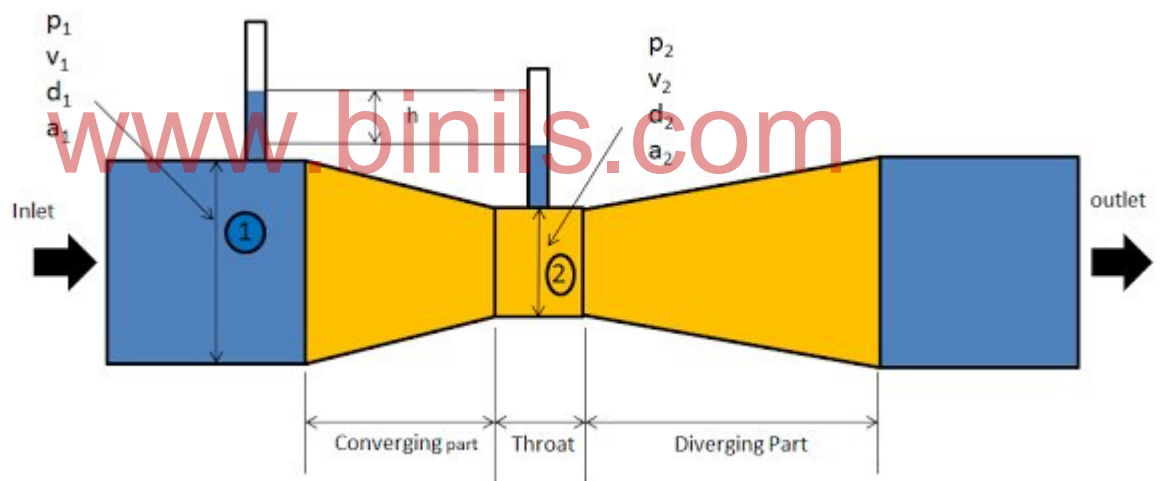

Fig.4.14

### Expression for the rate of flow through Venturimeter

Considered a venturimeter is fitted to a horizontal pipe through which fluid ( water) is flowing as shown in the figure given below.

Let  $d_1$ ,  $p_1$ ,  $v_1$  &  $a_1$ , are the diameter at the inlet, pressure at the inlet, velocity at the inlet and area at the cross section 1. And  $d_2$ ,  $p_2$ ,  $v_2$  and  $a_2$  are the corresponding values at section 2.

$$Q_{act} = C_d \frac{a_1 a_2}{\sqrt{a_1^2 - a_2^2}} \sqrt{2gh}$$

Where  $C_d$  is the coefficient of venturimeter and its value is less than 1.

### **PART –A**

1. Define Mechanical pressure transducer.
2. List the elastic pressure transducer.
3. List the types of manometer.
4. Name the manometric fluids.
5. What is the principle of working of Bi metallic thermometer?
6. Mention the application of Barometer?
7. What are types of Bourdon tube according to shapes?
8. What is principle of working of elastic elements?
9. Name the liquids used in thermometer?
10. What is the principle of working of orifice meter?
11. State Bernoulli's theorem.

### **PART-B**

1. Brief on elastic sensor.
2. What is the principle of working of Bourdon tube?
3. Differentiate between well type manometer and inclined tube manometer?
4. Write about manometric fluid?

### **PART-C**

1. Explain bourdon tube with neat diagram.
2. Describe bellows with neat diagram.
3. Explain the working of diaphragm with neat diagram.
4. Explain U-tube manometer with neat diagram.
5. Explain well manometer with neat diagram.
6. Explain inclined manometer with neat diagram.
7. Explain barometer with neat diagram.
8. Explain Ring balance manometer with neat diagram.
9. Explain Micro manometer with neat diagram.
10. Explain liquid-in-glass thermometer with neat diagram.
11. Explain filled system thermometer with neat diagram.
12. Explain how bi metallic thermometer works.
13. Explain venturi meter with neat diagram.
14. Explain how orifice meter is used to measure flow.

## UNIT – V ELECTRICAL TRANSDUCER

### 5.1 Resistive transducer:

Resistive transducers are those transducers in which the resistance change due to change in some physical phenomenon.

#### Variable resistive potentiometer:

##### Principle of working:

The resistance value of a wire depends on three parameters: resistivity, length and diameter.

Hence

$$R = \rho \frac{l}{A}$$

where

$R$  is the resistance ( $\Omega$ ),  $\rho$  is the resistivity of the material ( $\Omega\text{m}$ ),  $l$  is the length of the material (m),  $A$  is the cross-sectional area of the material ( $\text{m}^2$ )

The resistance value of a wire is

- Directly proportional to its resistivity and its length.
- Inversely proportional to cross-sectional area.

The potential difference (voltage) developed across any portion of the wire is directly proportional to the length of the wire with uniform cross sectional area when constant current flowing through it.



Fig.5.1

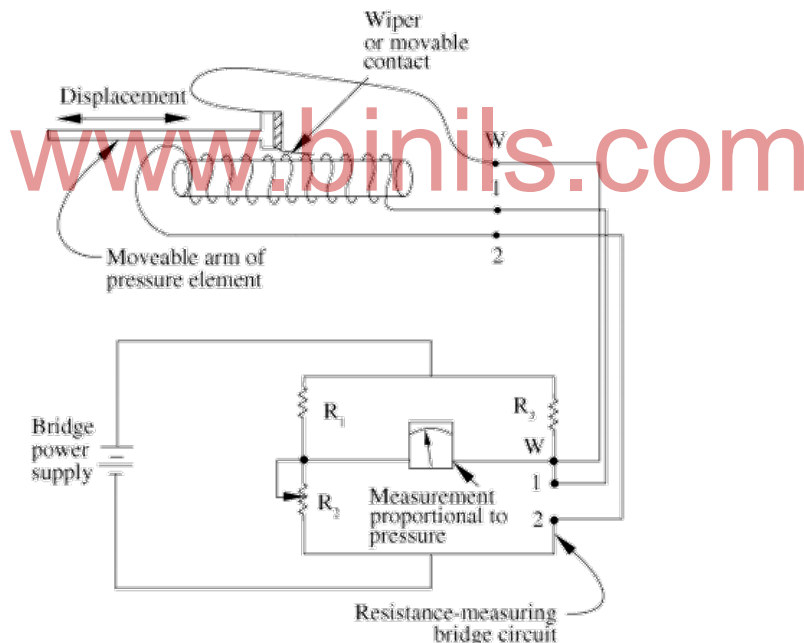

Fig.5.2

The resistive transducer consists of a movable contact driven by an active force-summing device. The movable contact, or wiper, travels across a resistive element that may be a wire-wound coil, a carbon ribbon, or a deposited conductive film. The motion of the wiper across the resistive element causes a change in the resistance selected by the wiper. The change in resistance produces an electric signal (either a change in voltage or current) that is proportional to the mechanical displacement of the wiper. This type of transducer may be excited using either AC or DC.

**Working of a potentiometer:**

The resistive potentiometer is also known as displacement-measuring device. In a potentiometer, an electrically conductive wiper slides across a fixed resistive element AB. A voltage  $V_T$  is applied across the two ends A and B of the resistance element. The wiper slides

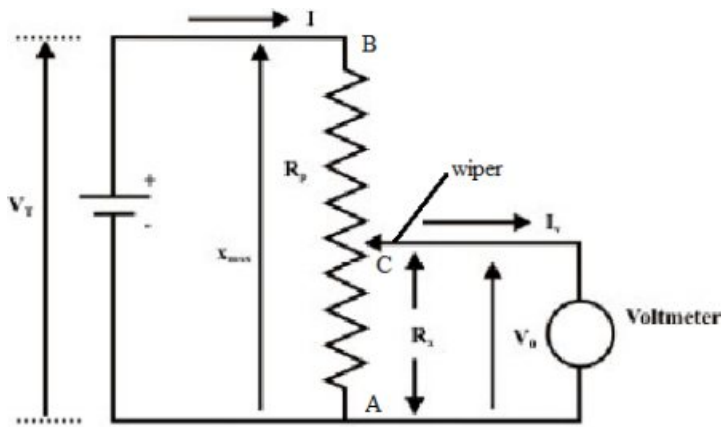

Fig.5.3

across a strip of resistive material. This resistive strip generally has a low resistance at one end, and its resistance gradually increases to a maximum resistance at the other end. An output voltage  $V_o$  is measured between the point of contact C of the sliding element and the end of the resistance element A.

A linear relationship exists between the output voltage  $V_o$  and the distance  $x$

**Types of potentiometers:**

According to construction there are two types.

**Translational potentiometer:**

It is also known as linear potentiometer. It consists of a resistance element with a movable contact called wiper.

www.binils.com

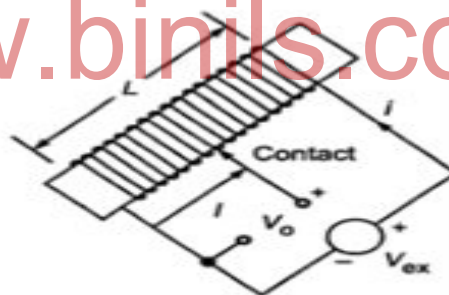

(a) Translational

Fig.5.4

**Rotary potentiometer:**

**Single-turn pot:**

In the single turn potentiometer, wire is wound on mandrel which is circular. Its entire range of the wiper is about  $270^\circ$  of a complete revolution.

**Multi-turn pot:**

Multiple rotations mostly 5, 10 or 20 turns for increased precision. They are constructed either with a wiper that follows a spiral or helix form.

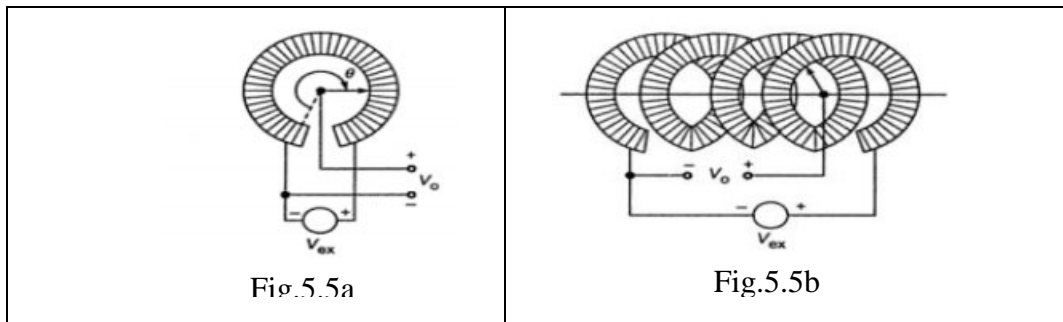

According to materials used there are five types of potentiometers:

wire wound, carbon film and plastic film potentiometers, carbon composition and cermet.

**1) Wire wound potentiometers:** This potentiometer comprises of several rounds of wire wound around the shaft of the non-conducting material. The turns of the coil are bonded together by an adhesive. In this case the slider, connected to the body whose displacement is to be measured, moves on the potentiometer track and it makes contacts with successive turns of the coil. The larger the number of turns of the coil, more is the resolution of the coil.

**2) Carbon film potentiometers:** The carbon film potentiometers are formed by depositing carbon composition ink on an insulating body, which in most of the cases is phenolic resin. The resolution is better than the wire wound potentiometers.

**3) Plastic film pots:** These pots comprise of the specially impregnated plastic material having resistance characteristics that are controlled properly. These can be used for rotary as well as translational slider movements. They have very good resolution better than the wire wound pots.

**4) Carbon composition:** The material used is a mixture of carbon and a filler material - determining the resistivity of the carbon composition film of the potentiometer element.

**5) Cermet:** Cermet is a composite material consisting of ceramic and a metal material. It is particularly applicable where any high temperatures may be experienced.

Conductive plastic: These are made from a form of conductive plastic

#### Applications:

- Linear displacement measurement
- Rotary displacement measurement
- Volume control
- Brightness control
- Liquid level measurements using floats

The body whose motion is being measured is connected to the sliding element of the potentiometer, so that translational motion of the body causes a motion of equal magnitude of the slider along the resistive element and a corresponding change in the output voltage  $V_o$ .

#### 5.2 Strain gauge:

##### Principle -Piezo-Resistive effect

Its principle is based on fact that the resistance of a wire increases with increasing strain and decreases with decreasing strain. This is piezoresistive effect.

The resistance change in metals is mostly due to the change of geometry resulting from applied mechanical stress. It is calculated using the simple resistance equation



$$R = \rho \frac{\ell}{A}$$

Where  $\ell$  - Conductor length [m]

A - Cross-sectional area of the current flow [m<sup>2</sup>]

$\rho$  - electric resistivity

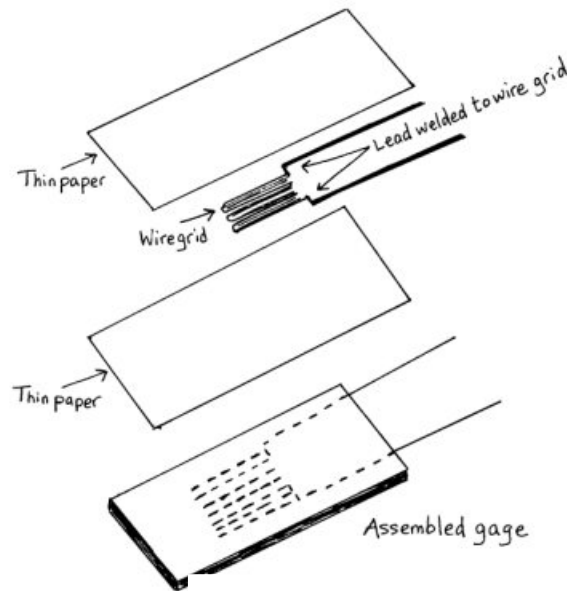

Fig.5.6

of bonded-wire type strain gage.

### Construction:

- A wire gauge was mounted and bonded between two thin pieces of paper.
- Strain gauges are normally attached to the member whose strain is being measured through a cement or adhesive.
- Adhesives and the gauge backing material transmit the force to the grid.

### Working:

To measure small changes in resistance which is due to change in measured quantity, strain gauges are almost always used in a bridge configuration with a voltage excitation source.

The general Wheatstone bridge, consists of four resistive arms with an excitation voltage,  $V_{EX}$ , that is applied across the bridge.

From this equation,

When  $R_1 = R_2 = R_4 = R_3$ , the voltage output  $V_O$  is zero. Under this condition, the bridge is said to be balanced.

When  $R_4$  is replaced with an active strain gage, any changes in the strain gage resistance ie if  $R_4 = R_G + \Delta R$  will unbalance the bridge and produce a nonzero output voltage.

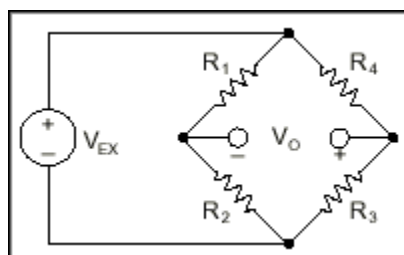

Fig.5.7

The output voltage of the bridge,  $V_o$ , is equal to:

$$V_o = \left[ \frac{R_3}{R_3 + R_4} - \frac{R_2}{R_1 + R_2} \right] \cdot V_{EX}$$

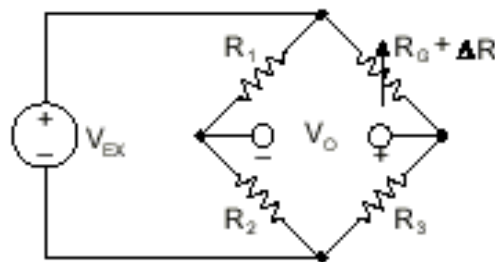

Fig.5.8

**Types :**

- 1) Semiconductor strain gauge
- 2) Unbonded strain gauge
- 3) Bonded strain gauge

**1)Semiconductor strain gauge:**

A typical semiconductor strain gauge is formed by the semiconductor technology i.e., the semiconducting wafers or filaments of length varying from 2 mm to 10 mm and thickness of 0.05 mm are bonded on suitable insulating substrates (for example Teflon). The gold leads are usually employed for making electrical contacts. The electrodes are formed by vapour deposition. The assembly is placed in a protective box as shown in the figure below.

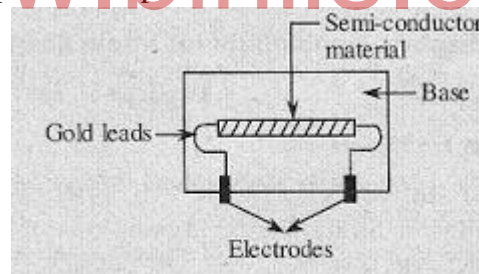

Semiconductor Strain gauge

Fig.5.9 a

The strain sensitive, elements used by the semiconductor strain gauge are the semiconductor materials such as, silicon and germanium. When the strain is applied to the semiconductor element a large change in resistance occurs which can be measured with the help of a wheatstone bridge. The strain can be measured with high degree of accuracy due to relatively high change in resistance. A temperature compensated semiconductor strain gauge can be used to measure small strains of the order of  $10^{-6}$  i.e, micro-strain. This type of gauge will have a gauge factor of  $130 \pm 10\%$  for a semiconductor material of dimension 1 x 0.5 x 0.005 inch having the resistance of 350  $\Omega$ .

**2)Unbonded strain gauge:**

An unbonded strain gauge has a resistance wire stretched between two frames. The rigid pins of the two frames are insulated. When the wire is stretched due to an applied force,

there occurs a relative motion between the two frames and thus a strain is produced, causing a change in resistance value. This change of resistance value will be equal to the strain input.

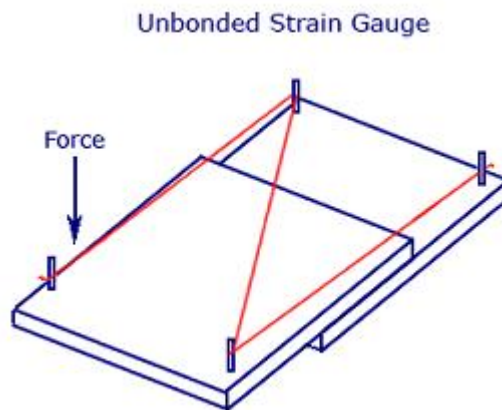

Fig.5.9 b

### 3) Bonded strain gauge:

A bonded strain gauge will be either a wire type or a foil type as shown in the figure below. It is connected to a paper or a thick plastic film support. The measuring leads are soldered or welded to the gauge wire. The bonded strain gauge with the paper backing is connected to the elastic member whose strain is to be measured.

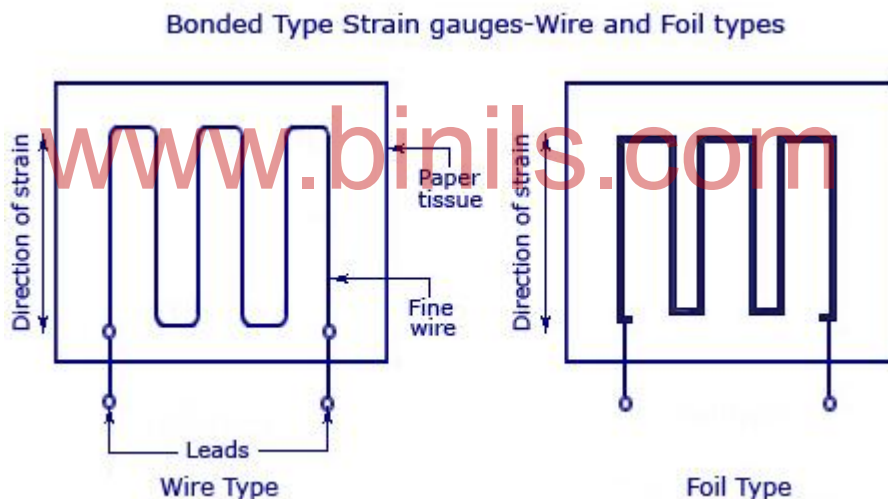

Fig.5.9 c

### 5.3 RTD: - Resistance Temperature Detector:

#### Principle of operation of an RTD:

When the temperature of an object increases or decreases, the resistance also increases or decreases proportionally.

The resistance of an RTD varies directly with temperature:

- As temperature increases, resistance increases.
- As temperature decreases, resistance decreases.

### Construction:

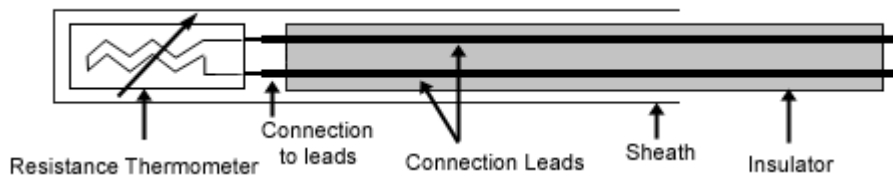

Fig.5.10

RTD elements are usually long, spring-like wires surrounded by an insulator and enclosed in a sheath of metal. Insulator is porcelain insulator. The insulator prevents a short circuit between the wire and the metal sheath. Inconel, a nickel-iron-chromium alloy, is normally used in manufacturing the RTD sheath because of its inherent corrosion resistance.

### Working:

When placed in a liquid or gas medium, the Inconel sheath quickly reaches the temperature of the medium. The change in temperature will cause the platinum wire to heat or cool, resulting in a proportional change in resistance. This change in resistance is then measured by a precision resistance measuring device that is calibrated to give the proper temperature reading. This device is normally a bridge circuit and the output voltage is proportional to the resistance change which is in turn proportional to the temperature change.

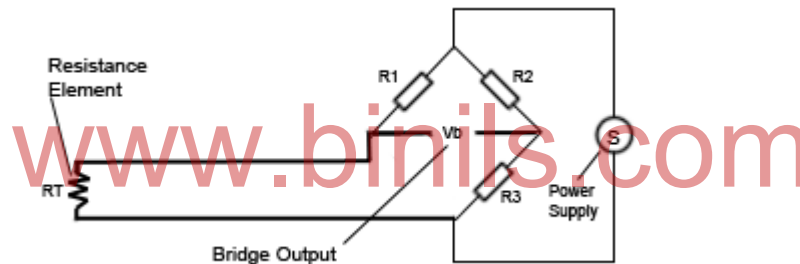

Fig.5.11

### Materials used:

Sensing element used in a RTD is a metal. As platinum is the most commonly used metal for making RTD's, the device can also be called Platinum Resistance Thermometers (PRT's). Platinum, Nickel and Copper are the most commonly used sensing elements. PRT is known to measure temperatures as high as 1500 degree Fahrenheit while copper and Nickel can measure only a maximum of 400 degree Fahrenheit.

$$\frac{\Delta R}{R_0} = \alpha \Delta T \quad \alpha = \text{temperature coefficient of resistance.}$$

$$\frac{R - R_0}{R_0} = \alpha(T - T_0) \quad \text{or} \quad R = R_0[1 + \alpha(T - T_0)]$$

Where  $\alpha$  is for:

Platinum- 0.003927

Copper- 0.0068

### Application:

Air conditioning, Food processing, Textile production.

## 5.4 Thermocouple

The thermocouple is a transducer that converts thermal energy into electrical energy.

### Construction:

A thermocouple is constructed of two dissimilar metal wires joined at one end. When one end of each wire is connected to a measuring instrument, the thermocouple becomes a sensitive and highly accurate measuring device.

The leads of the thermocouple are encased in a rigid metal sheath. The measuring junction is normally formed at the bottom of the thermocouple housing. Magnesium oxide surrounds the thermocouple wires to prevent vibration that could damage the fine wires and to enhance heat transfer between the measuring junction and the medium surrounding the thermocouple.

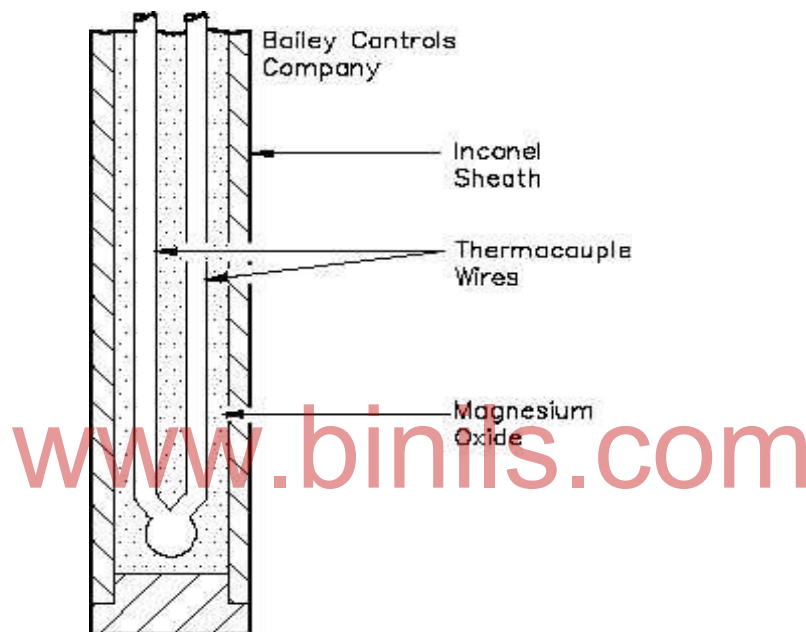

Fig.5.12

### Working:

Heating the junction of the thermocouple produces a voltage which is greater than the voltage across the reference junction. The difference between the two voltages is proportional to the difference in temperature and can be measured by a voltmeter in terms of millivolt.

### Materials used:

Thermocouples may be constructed of several different combinations of materials. The performance of a thermocouple material is generally determined by using that material with platinum.

Chromel-Constantan is excellent for temperatures up to 2000°F;

Nickel/Nickel-Molybdenum sometimes replaces Chromel-Alumel;

Tungsten-Rhenium is used for temperatures up to 5000°F.

Some combinations used for specialized applications are Chromel-White Gold, Molybdenum-Tungsten, Tungsten-Iridium, and Iridium/Iridium-Rhodium.

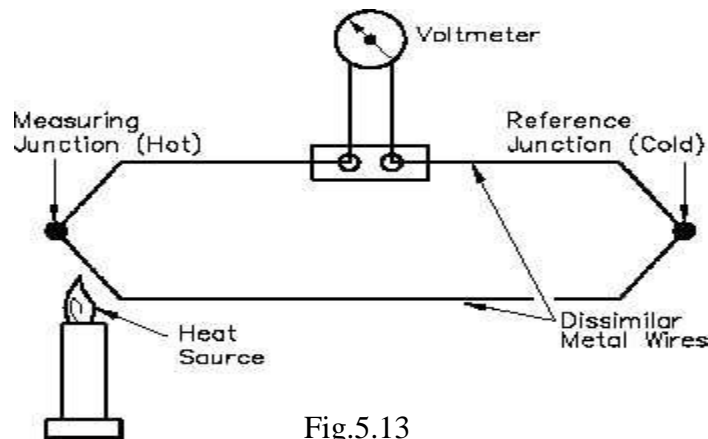

Fig.5.13

## 5.5 Thermistor:

### Symbol:



Thermistor is the short form for 'Thermal Resistor'. The thermistors respond negatively to the temperature.

The resistance of the thermistors decreases with the increase its temperature. The resistance of thermistor is given by:  $R = R_0 e^k$

Where  $K = \beta(1/T - 1/T_0)$

Where R is the resistance of the thermistor at any temperature T in °K (degree Kelvin)

$R_0$  is the resistance of the thermistor at particular reference temperature  $T_0$  in °K

$\beta$  is a constant whose value ranges from 3400 to 3900 depending on the material



The thermistors are made up of ceramic like semiconducting materials, sintered mixtures of oxides of metals such as manganese, nickel, cobalt, and iron of about 100 to 450,000 ohm-cm. Their resistances range from 0.4 ohms to 75 mega-ohms and they may be fabricated in wide variety of shapes like disc, rod, washer, and bead.

### Working:

Thermistor is placed on the body whose temperature is to be measured. It is also connected in the electric circuit. When the temperature of the body changes, the resistance of the thermistor also changes, which is indicated by the circuit directly as the temperature since resistance is calibrated against the temperature. The thermistor can also be used for some control which is dependent on the temperature.

## Types

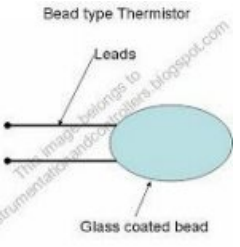
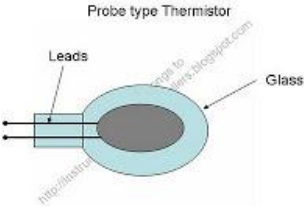
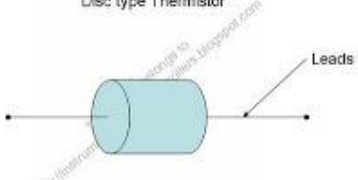
### Based on construction:

Bead type	probe type	disc type	washer type
 <p>Smallest Thermistors are in the form of heads with a diameter of 0.15mm to 1.25mm. This is the most familiar type of Thermistor usually glass coated.</p>	 <p>Beads may be sealed in the tips of solid glass rods to form probes. Glass probe have a diameter of about 2.5mm. the probes are used for measuring temperature of liquids.</p>	 <p>Discs are made by pressing material under high pressure into cylindrical flat shapes with diameters ranging from 2.5mm to 25mm. they are mainly used for temperature control.</p>	 <p>Washer type is usually a long cylindrical units. Leads are attached to the ends of the rods. The advantage of this type is, it produces high resistance under moderate power.</p>

### Based on thermal coefficient:

There are two types of thermistor:

- (i) negative temperature coefficient (NTC) – the resistance of the thermistor falls with increasing temperature
- (ii) positive temperature coefficient (PTC) - the resistance of the thermistor rises with increasing temperature

### Applications:

Thermistors are used as temperature sensors in thermostats in ovens and iron box, in fire alarms and on the wing of a plane to detect when the temperature falls low enough for ice to form. They are also in use in premature baby units to detect when a baby may have stopped breathing, current limiting devices and thermometers.

### R Vs Temperature Characteristics of RTD, Thermocouple & Thermister

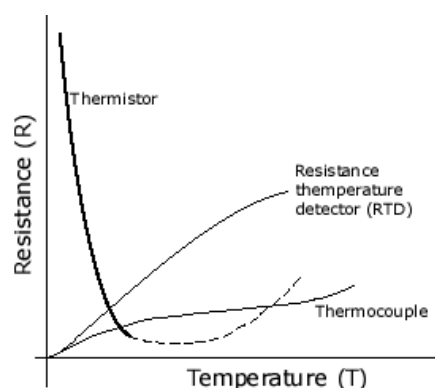

Fig.5.14

## 5.6 Semiconductor temperature sensors:

The semiconductor (or IC for integrated circuit) temperature sensor is an electronic device fabricated as other modern electronic semiconductor components such as microprocessors. Semiconductor temperature sensors are available from a number of manufacturers. The AD590 and the LM35 have traditionally been the most popular devices.

These sensors share a number of characteristics - linear outputs, relatively small size, limited temperature range (-40 to +120°C typical), low cost, good accuracy if calibrated but also poor interchangeability. The most popular semiconductor temperature sensors are based on the fundamental temperature and current characteristics of the transistor.

If two identical transistors are operated at different but constant collector current densities, then the difference in their base-emitter voltages is proportional to the absolute temperature of the transistors. This voltage difference is then converted to a single ended voltage or a current. An offset may be applied to convert the signal from absolute temperature to Celsius or Fahrenheit.

In general, the semiconductor temperature sensor is best suited for embedded applications. This is because they tend to be electrically and mechanically more delicate than most other temperature sensor types.

### Thermodiode temperature sensors:

The ordinary semiconductor diode may be used as a temperature sensor. The forward biased voltage across a diode has a temperature coefficient of about 2.3mV/°C and is reasonably linear. The bias current should be held as constant as possible - using constant current source, or a

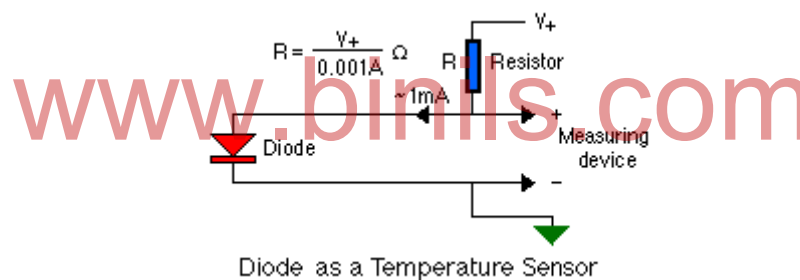
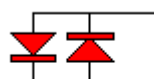

Fig.5.15

resistor from a stable voltage source. Without calibration the initial error is likely to be too large - in the order of  $\pm 30^\circ\text{C}$  - the largest of all the contact type temperature sensors. This initial error is greatly reduced if sensor grade parts are used.

One advantage of the diode as a temperature sensor is that it can be electrically robust - tolerant to voltage spikes induced by lightning strike. This is particularly true if power diodes (e.g. the common 1N4004) are used and a second back to back diode is used to limit power dissipation during high peak currents.



Back to Back Diodes

Fig.5.16

Thermo transistor sensor is used in diode mode by connecting the base and collector together. Also the sensor is wired between base and emitter and the excitation current reduced by a factor of about 100.

**Advantages:** Very low power, sensitive and linear sensor.



## Applications:

Used in embedded systems.

### 5.7 Inductive transducers:

LVDT is an inductive transducer is used for converting a linear motion into an electrical signal.

#### Construction:

The device consists of a primary winding (P) and two secondary windings namely S1 and S2. Both of them are wound on one cylindrical former, side by side, and they have equal number of turns. Their arrangement is such that they maintain symmetry with either side of the primary winding (P). A movable soft iron core is placed parallel to the axis of the cylindrical former. An arm is connected to the other end of the soft iron core and it moves according to the displacement produced.

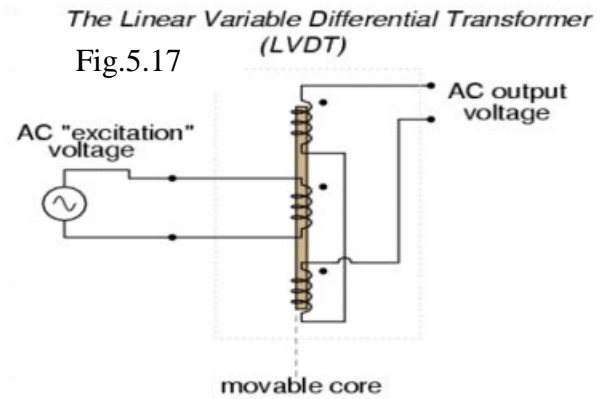

Fig.5.17

#### Working:

As shown in the figure 5.16, an ac voltage with a frequency between (50-400) Hz is supplied to the primary winding. Thus, two voltages  $V_{S1}$  and  $V_{S2}$  are induced at the two secondary windings S1 and S2 respectively. The output voltage will be the difference between the two voltages ( $V_{S1}-V_{S2}$ ) as they are combined in series.

Consider three different positions of the soft iron core inside the former.

**Null Position** – This is also called the central position as the soft iron core will remain in the exact center of the former. Thus the linking magnetic flux produced in the two secondary windings will be equal. The voltage induced because of them will also be equal. Thus the resulting voltage  $V_{S1}-V_{S2} = 0$ .

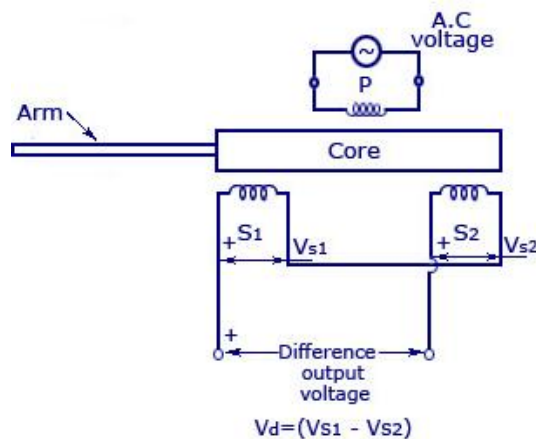

Fig.5.18

**Right of Null Position** – In this position, the linking flux at the winding S2 has a value more than the linking flux at the winding S1. Thus, the resulting voltage  $V_{S1}-V_{S2}$  is negative and  $V_{S1}$  will be 180 degrees out of phase with  $V_{S2}$ .

Left of Null Position – In this position, the linking flux at the winding S2 has a value less than the linking flux at the winding S1. Thus, the resulting voltage  $V_{S1}-V_{S2}$  is positive and  $V_{S1}$  will be in phase with  $V_{S2}$ .

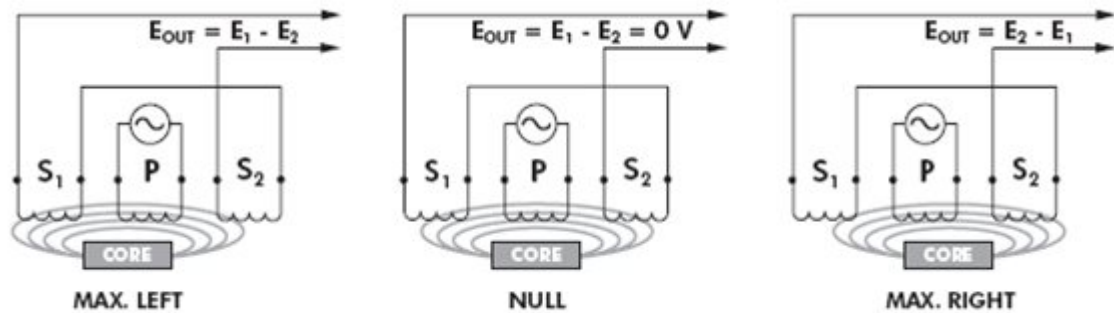

Fig.5.19

From the working it is clear that the difference in voltage,  $V_{S1}-V_{S2}$  will depend on the right or left shift of the core from the null position. Also, the resulting voltage is in phase with the primary winding voltage for the change of the arm in one direction, and is 180 degrees out of phase for the change of the arm position in the other direction. The magnitude and displacement can be easily calculated or plotted by calculating the magnitude and phase of the resulting voltage.

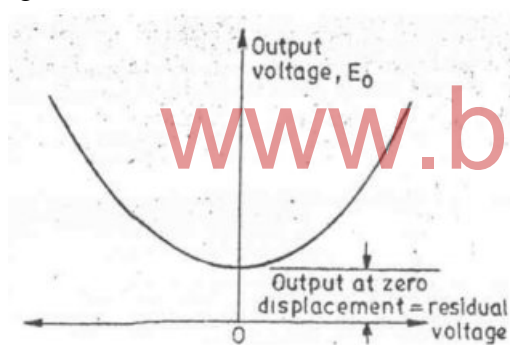

Fig.5.20

#### Applications:

- LVDT are used for measurement of tension in cord.
- LVDT are used for measurement and control of thickness of a metal sheet being rolled.
- The LVDT can be used in all application where displacement ranging from fraction of a mm to few cm have to be measured

#### 5.8 Variable capacitance transducer:

The capacitive transducer or sensor is a capacitor with variable capacitance and is called as Capacitive Transducer or Capacitive Sensor or Variable Capacitance Transducer.

Construction:

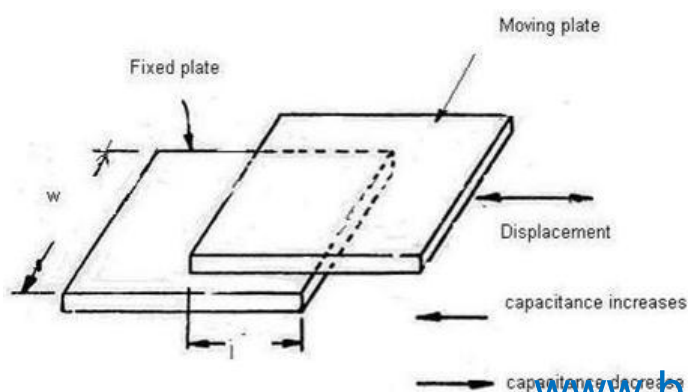

Fig.5.21

The capacitive transducer comprises of two parallel metal plates that are separated by the material air, which is called as the dielectric material. The distance between the two plates is variable.

**Dielectric medium:**

Solid dielectric materials :porcelain (ceramic), mica, glass, plastics, polyethylene and the oxides of various metals.

Gases: air, dry gases such as helium and nitrogen

Liquids : Distilled water .

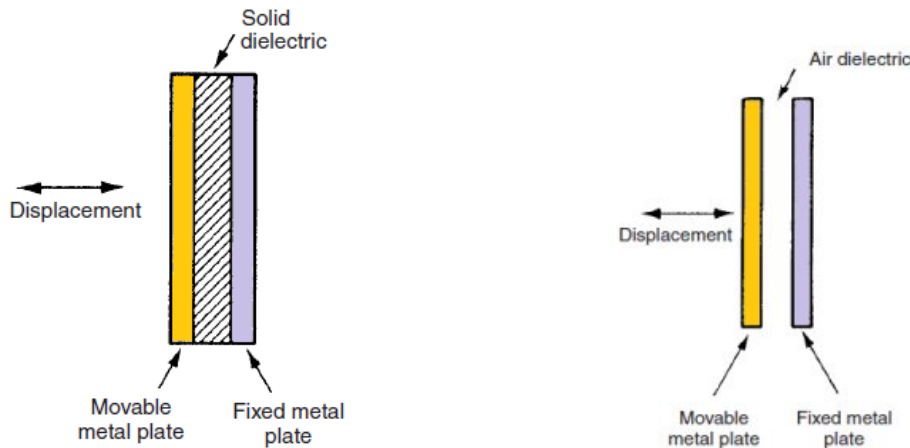

Fig.5.22

Vacuum is an exceptionally efficient dielectric.

Due to a potential difference across the conductors, an electric field develops across the insulator. This causes the positive charges to accumulate on one plate and the negative charges to accumulate on the other. The capacitor value is usually denoted by its capacitance, which is measured in Farads

The capacitance C between the two plates of capacitive transducers is given by:

$$C = \epsilon_0 \cdot \epsilon_r \cdot A / d$$

Where C is the capacitance of the capacitor or the variable capacitance transducer

$\epsilon_0$  is the absolute permittivity;  $\epsilon_r$  is the relative permittivity

The product of  $\epsilon_0$  &  $\epsilon_r$  is also called as the dielectric constant of the capacitive transducer.

A is the area of the plates; D is the distance between the plates

From the above formula (shown in the figure below as a,b,c) the capacitance of the capacitive transducer depends on the changes with the change in

- a. the area of the plates
- b. the distance between the plates
- c. the dielectric constant of the dielectric material used in it.

**a) Changing Area of the Plates of Capacitive Transducers**

The capacitance of the variable capacitance transducer also changes with the area of the two plates. This principle is used in the torquemeter, used for measurement of the torque on the shaft. This comprises of the sleeve that has teeth cut axially and the matching shaft that has similar teeth at its periphery.

**b) Changing Distance between the Plates of Capacitive Transducers**

In these types of capacitive transducers, the distance between the plates is variable, while the area of the plates and the dielectric constant remain constant. This is the most commonly used type of variable capacitance transducer. For measurement of the displacement of the object, one plate of the capacitance transducer is kept fixed, while the other is connected to the object.

When the object moves, the plate of the capacitance transducer also moves, this results in change in distance between the two plates and the change in the capacitance. The changed capacitance is measured easily and it calibrated against the input quantity, which is displacement. This principle can also be used to measure pressure, velocity, acceleration etc.

### c) Changing Dielectric Constant type of Capacitive Transducers

In these capacitive transducers, the dielectric material between the two plates changes, due to which the capacitance of the transducer also changes. When the input quantity to be measured changes the value of the dielectric constant also changes so the capacitance of the instrument changes. This capacitance, calibrated against the input quantity, directly gives the value of the quantity to be measured. This principle is used for measurement of level in the hydrogen container, where the change in level of hydrogen between the two plates results in change of the dielectric constant of the capacitance transducer. Apart from level, this principle can also be used for measurement of humidity and moisture content of the air.

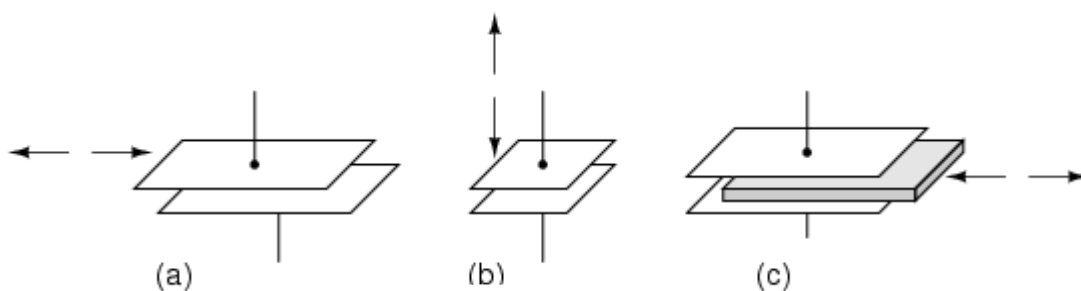

Fig.5.23

(a) area of overlap (b) distance between plates (c) dielectric between plates.

## 5.9 Piezo-electric transducer:

### Piezoelectric effect:

The piezoelectric effect is that these materials, when subjected to mechanical stress, generate an electric charge( voltage) proportional to that stress. Piezoelectricity is the ability of certain crystalline materials to convert mechanical energy into electrical energy and vice versa.

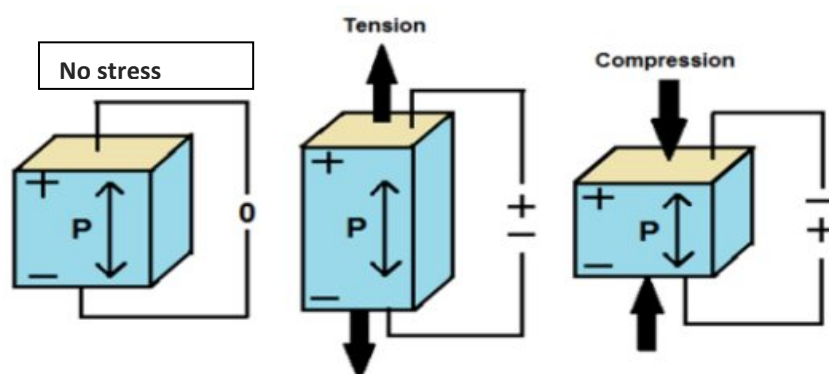

Fig.5.24

### Piezoelectric materials:

Some naturally occurring crystalline materials that possess this property are quartz and tourmaline.

Some artificially produced piezoelectric crystals are Rochelle salt, ammonium dihydrogen phosphate and lithium sulphate, barium titanate (BaTi), lead titanate (PbTi), lead metaniobate (PbNb<sub>2</sub>O<sub>6</sub>) and Bismuth titanate (Bi<sub>4</sub>Ti<sub>3</sub>O<sub>12</sub>), polyvinylidene fluoride (PVDF)

Modes of operation:

The directional parameters are given the subscripts 1,2 and 3 corresponding to the directions of x, y and z, respectively. Mechanical shear stresses (couples) about x, y and z, and the corresponding shear strains, are designated with the subscripts 4, 5 and 6, respectively.

The piezoelectric crystal bends in different ways at different frequencies. This bending is called the vibration mode. The crystal can be made into various shapes to achieve different vibration modes. To realize small, cost effective, and high performance products, several modes have been developed to operate over several frequency ranges. These modes allow us to make products working in the low kHz range up to the MHz range.

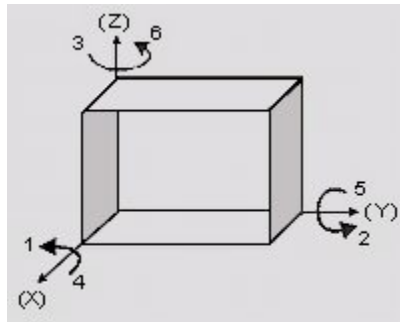

Fig.5.25

**Properties of piezoelectric materials:**

- high value of the dielectric constant
- presence of spontaneous polarization in some zones (domains)
- presence of hysteresis loop in polarization-electric field and strain-electric field curves
- dielectric constant increases with increase of temperature
- ferroelectric properties disappear above a special point in dielectric constant - temperature curve (Curie point)

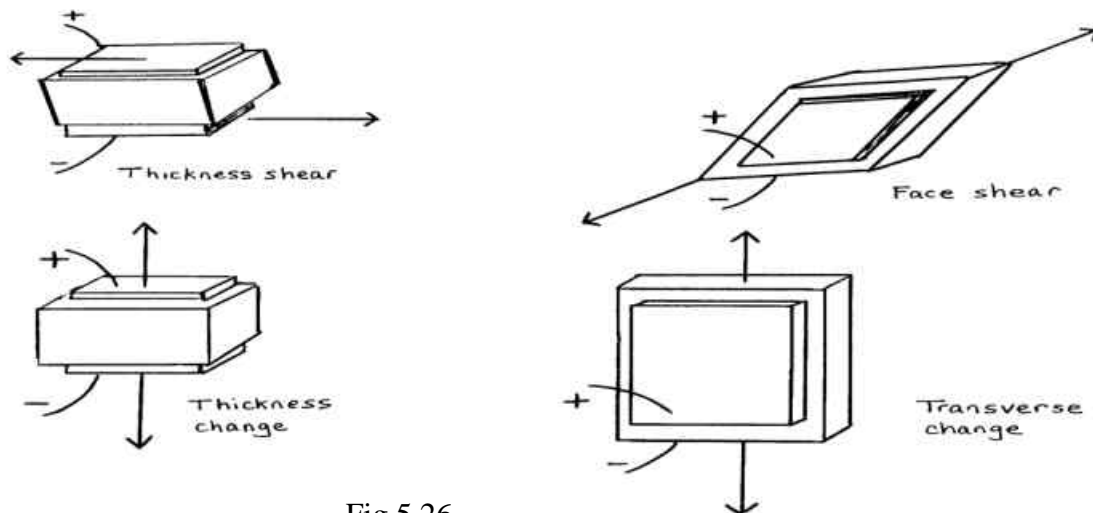

Fig.5.26

**Equivalent circuit (electrical model):**

A piezoelectric sensor can be represented by the equivalent circuit as follows.

- The first equivalent circuit is based on parallel combination of series RC circuits of crystal.
- The second one is given by series combination of parallel RC circuits that includes cable and amplifier.

- Both models must be optimised for total capacitance and phase frequency dependence. Equivalent circuit (electrical model) describe sensor electrical properties such as the admittance impedance characteristic and also signal to noise ratio. The value of Capacitance of the mechanical circuit must be much smaller than vacuum capacitance. The voltage  $e_o$  at the source is directly proportional to the applied force, pressure, or strain. The output signal is then related to this mechanical force as if it had passed through the equivalent circuit.

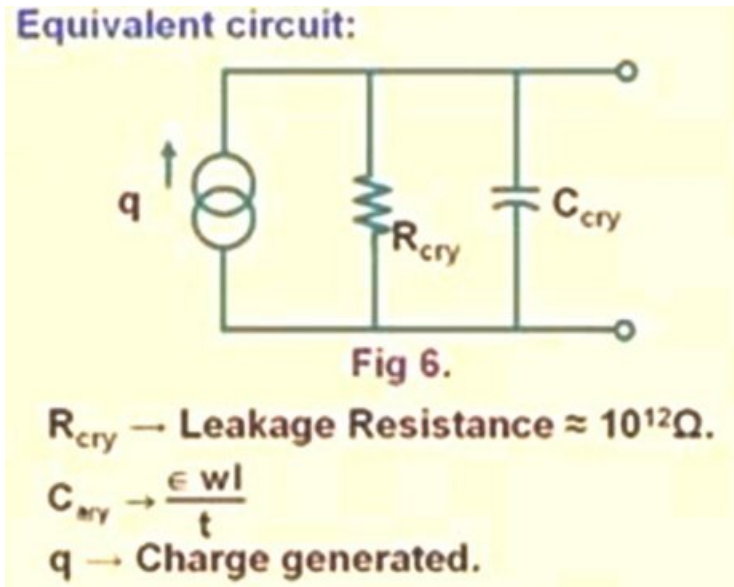

[www.binils.com](http://www.binils.com)

### **PART-A**

1. Write the principle of potential meter?
2. Write the principle of strain gauge?
3. Write the principle of thermocouple?
4. Write the principle of LVDT?
5. Write the principle of piezo electric transducer?
6. List the types of strain gauge?
7. Why the temperature coefficient is positive for RTD?
8. Why the temperature coefficient is negative for thermistor?
9. List the piezo electric materials?
10. Draw the equivalent circuit for piezo electric transducer?
11. Expand LVDT?

### **PART-B**

1. What is piezo-resistive effect? Which transducer works under this principle?
2. List the types of thermistor?
3. What is the application of LVDT?
4. What are the modes of operation of piezo electric crystal?
5. What are the properties of piezo electric crystal?

### **PART-C**

1. Explain with a neat diagram the working of potentiometer?
2. Explain with a neat diagram the working of strain gauge?
3. Explain with a neat diagram the working of RTD?
4. Explain with a neat diagram the working of thermocouple?
5. Explain with a neat diagram the working of thermistor?
6. Explain with a neat diagram the working of thermo diodes & transistors?
7. Explain with a neat diagram the working of LVDT?
8. Explain with a neat diagram the working of variable capacitance transducer?
9. Explain with a neat diagram the working of piezo electric transducer?